

HCD-MD313

SERVICE MANUAL

Self Diagnostics
Supported model

Canadian Model
AEP Model
UK Model
E Model



HCD-MD313 is the amplifier, CD, MD and tuner section in DHC-MD313.

US and foreign patents licensed from Dolby Laboratories Licensing Corporation.

CD Section	Model Name Using Similar Mechanism	HCD-T1
	CD Mechanism Type	CDM13C-5BD19
	Base Unit Name	BU-5BD19
	Optical Pick-up Name	KSS-213B/K-N
MD Section	Model Name Using Similar Mechanism	MDS-MX1
	MD Mechanism Type	MDM-3D
	Optical Pick-up Name	KMS-260A/J1N

SPECIFICATIONS

Amplifier section

Canadian model:

Continuous RMS power output
20+20 watts
(6 ohms at 1 kHz, 1% THD, 120 V) (Rated)
25+25 watts
(6 ohms at 1 kHz, 10% THD, 120 V) (Reference)

European model:

DIN power output (Rated)
25 + 25 watts (6 ohms at 1 kHz, DIN, 230 V)

Continuous RMS power output (Reference)
30+30 watts
(6 ohms at 1 kHz, 10% THD, 230 V)

Music power output

(Reference)
50+50 watts

Other models:

DIN power output (Rated)
20+20 watts
(6 ohms at 1 kHz, DIN, 240 V)
18+18 watts
(6 ohms at 1 kHz, DIN, 220 V)

Continuous RMS power output (Reference)
25+25 watts (6 ohms at 1 kHz, 10% THD, 240 V)
23+23 watts
(6 ohms at 1 kHz, 10% THD, 220 V)

Peak music power output 400 watts

Inputs

TAPE IN (phono jacks):
voltage 250 mV/125 mV, impedance 47 kilohms

Frequency response

surface on the Optical Pick-up Block with a 7 mm aperture.

2 Hz - 20 kHz

Outputs

TAPE OUT (phono jacks):
voltage 250 mV impedance 1 kilohms

MD deck section
System

MiniDisc digital audio system

Laser

Semiconductor laser ($\lambda = 780 \text{ nm}$)

PHONES (Stereo minijack):

accepts headphones of 8 ohms or more.

Laser output

Emission duration: continuous

Max. 44.6 μW^*

SPEAKER:

accepts impedance of 6 to 16 ohms.

CD player section

System

Compact disc and digital audio system
Semiconductor laser ($\lambda = 780 \text{ nm}$)

Recording time

74 minutes max. (using MDW-74)

Laser

Emission duration: continuous

Sampling frequency

44.1 kHz

Laser output

Max. 44.6 μW^*
*This output is the value measured at a distance of 200 mm from the objective lens

Frequency response

5 Hz to 20 kHz

— Continued on next page —

MINI Hi-Fi COMPONENT SYSTEM



SONY®

Tuner section

FM stereo, FM/AM superheterodyne tuner

FM tuner section

Tuning range	87.5 – 108.0 MHz (50 kHz step)
Aerial	FM lead aerial
Aerial terminals	75 ohms unbalanced
Intermediate frequency	10.7 MHz

AM tuner section

Tuning range	
North American model:	
AM:	530 – 1,710 kHz (with the interval set at 10 kHz) 531 – 1,710 kHz (with the interval set at 9 kHz)
European model:	
MW:	522 – 1,611 kHz (with the interval set at 9 kHz)
LW:	144 – 288 kHz (with the interval set at 3 kHz)
Other models:	
MW:	531–1,602 kHz (with the interval set at 9 kHz) 530 – 1,710 kHz (with the interval set at 10 kHz)
SW:	5.95 – 17.90 MHz (with the interval set at 5 kHz)

General

Power requirements	
North American model:	120 V AC, 60 Hz
European model:	220 – 230 V AC, 50/60 Hz
Other models:	110 – 120 V or 220 – 240 V AC, 50/60 Hz
Power consumption:	
North American model:	70 watts
Other models:	80 watts

Dimensions

Amplifier/Tuner/MD/CD section:	Approx. 215 × 150 × 320 mm (8 ¹ / ₄ × 6 × 12 ⁵ / ₈ in) (w/h/d) incl. projecting parts and controls
--------------------------------	---

Mass

Amplifier/Tuner/MD/CD section:	Approx. 5.5 kg (12 lb 8 oz.)
--------------------------------	------------------------------

Supplied accessories:	Remote RM-MD313 (1) AA (R6) batteries (2) AM loop aerial (1) FM lead aerial (1)
-----------------------	--

Design and specifications are subject to change without notice.

TABLE OF CONTENTS

SELF-DIAGNOSIS DISPLAY	2
1. SERVICING NOTES	3
2. GENERAL	5
3. DISASSEMBLY	8
4. TEST MODE	15
5. ELECTRICAL ADJUSTMENTS	
MD Section	19
CD Section	24
6. DIAGRAMS	
6-1. Block Diagrams	
CD Section	27
MD Section	29
Main Section	31
6-2. Printed Wiring Board — CD Section —	33
6-3. Schematic Diagram — CD Section —	35
6-4. Printed Wiring Boards — MD Section —	39
6-5. Schematic Diagram — MD Section —	41
6-6. Schematic Diagram — Main Section —	46
6-7. Printed Wiring Boards — Main Section —	51
6-8. Printed Wiring Board — Audio Section —	53
6-9. Schematic Diagram — Audio Section —	55
6-10. Printed Wiring Boards — Panel/Power Section —	58
6-11. Schematic Diagram — Panel/Power Section —	61
6-12. IC Pin Function Description	74
7. EXPLODED VIEWS	82
8. ELECTRICAL PARTS LIST	88

SELF-DIAGNOSIS DISPLAY

This system has the Self-diagnosis display function to let you know if there is a system malfunction. The display shows a code made up of three letters and a message alternately to show you the problem. To solve the problem refer to the following list. If any problem persists, consult your nearest Sony dealer.

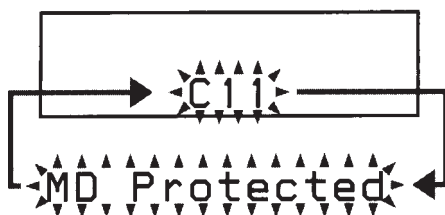

C11/MD Protected

The MD is protected against erasure.
→Remove the MD and slide the tab to close the slot (page 28)

C12/REC Error

Recording is not possible.
→Move the system to a stable place and start recording over from the beginning
The MD is dirty or is scratched or the MD does not meet the standards.
→Change the MD with another one and start recording over from the beginning.

C13/Disc Error

The MD deck cannot read the disc information correctly.
→Eject the MD once, then insert it again.

C14/Disc Error

The MD deck cannot read the disc information correctly.
→Change the MD with another one.
→Erase all the recorded contents of the MD using the Erase function on page 39.

SECTION 1 SERVICING NOTES

MODEL IDENTIFICATION — BACK PANEL —

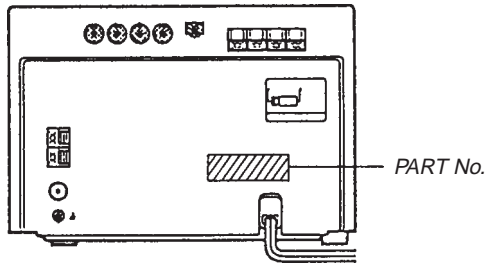

MODEL	PARTS No.
AEP, UK, German, AED models	4-993-849-1□
Hong Kong, Malaysia, Singapore models	4-993-849-2□
Canadian model	4-993-849-3□

- Abbreviation
AED: North European

Note:

Be sure to connect all wires (including FFC) in the MD section before applying power or ICs may be damaged.

SAFETY-RELATED COMPONENT WARNING!!

COMPONENTS IDENTIFIED BY MARK \triangle OR DOTTED LINE WITH MARK \triangle ON THE SCHEMATIC DIAGRAMS AND IN THE PARTS LIST ARE CRITICAL TO SAFE OPERATION. REPLACE THESE COMPONENTS WITH SONY PARTS WHOSE PART NUMBERS APPEAR AS SHOWN IN THIS MANUAL OR IN SUPPLEMENTS PUBLISHED BY SONY.

ATTENTION AU COMPOSANT AYANT RAPPORT À LA SÉCURITÉ!

LES COMPOSANTS IDENTIFIÉS PAR UNE MARQUE \triangle SUR LES DIAGRAMMES SCHÉMATIQUES ET LA LISTE DES PIÈCES SONT CRITIQUES POUR LA SÉCURITÉ DE FONCTIONNEMENT. NE REMPLACER CES COMPOSANTS QUE PAR DES PIÈCES SONY DONT LES NUMÉROS SONT DONNÉS DANS CE MANUEL OU DANS LES SUPPLÉMENTS PUBLIÉS PAR SONY.

NOTES ON HANDLING THE OPTICAL PICK-UP BLOCK OR BASE UNIT

The laser diode in the optical pick-up block may suffer electrostatic break-down because of the potential difference generated by the charged electrostatic load, etc. on clothing and the human body.

During repair, pay attention to electrostatic break-down and also use the procedure in the printed matter which is included in the repair parts.

The flexible board is easily damaged and should be handled with care.

NOTES ON LASER DIODE EMISSION CHECK

The laser beam on this model is concentrated so as to be focused on the disc reflective surface by the objective lens in the optical pick-up block. Therefore, when checking the laser diode emission, observe from more than 30 cm away from the objective lens.

Notes on chip component replacement

- Never reuse a disconnected chip component.
- Notice that the minus side of a tantalum capacitor may be damaged by heat.

Flexible Circuit Board Repairing

- Keep the temperature of soldering iron around 270 °C during repairing.
- Do not touch the soldering iron on the same conductor of the circuit board (within 3 times).
- Be careful not to apply force on the conductor when soldering or unsoldering.

CAUTION

Use of controls or adjustments or performance of procedures other than those specified herein may result in hazardous radiation exposure.

Laser component in this product is capable of emitting radiation exceeding the limit for Class 1.

CLASS 1 LASER PRODUCT
LUOKAN 1 LASERLAITE
KLASS 1 LASERAPPARAT

This appliance is classified as a CLASS 1 LASER product. The CLASS 1 LASER PRODUCT MARKING is located on the rear exterior.

CAUTION	; INVISIBLE LASER RADIATION WHEN OPEN, AVOID EXPOSURE TO BEAM.
ADVARSEL	; USYNLIG LASERSTRÅLING VED ÅBNING NÅR SIKKERHEDSAFBRYDERE ER UDE AF FUNKTION. UNNGÅ UDSÆTTELSE FOR STRÅLING.
VARO!	; AVATTAESSA JA SUOJALUKITUS OHTETTAESSA DLET ALTIINA LASERSAATELIVILLE.
WARNING	; LASERSTRÅLING NÅR DENNA DEL ÅR OPPNÅD OCH SPARREN ÅR URKOPPLAD.
ADVARSEL	; USYNLIG LASERSTRÅLING NÅR DEKSEL ÅPNES UNNGÅ EKSPONERING FOR STRÅLEN.

This caution label is located inside the unit.

DISC TABLE GETTING OUT PROCEDURE ON THE POWER SUPPLY IS OFF

1. Insert the tweezers to a hole on bottom of the chassis as shown a figure, then turn fully it toward direction ②.
2. Pull out the disc table.

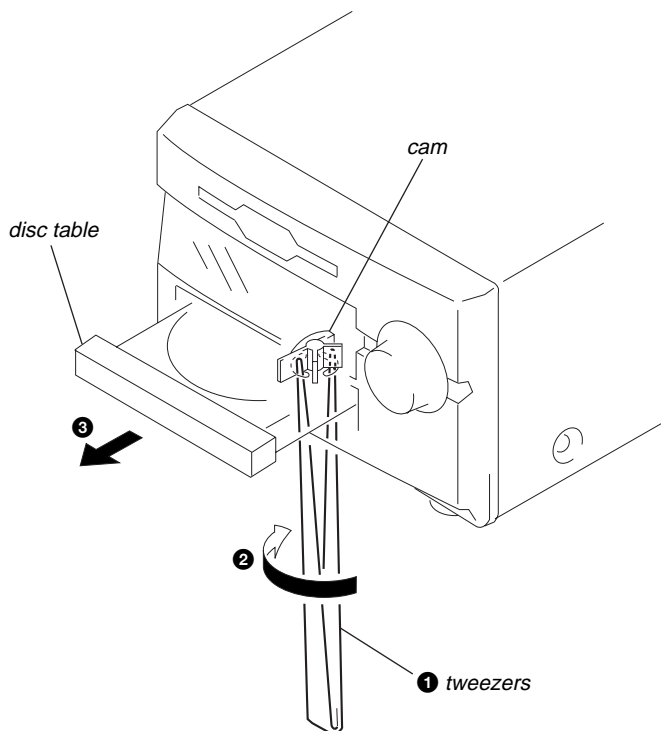

FLUORESCENT INDICATOR TUBE/BUTTONS/JOG/LEDs CHECK MODE

1. Press two buttons **PLAY MODE** and **■** (MD) simultaneously for standby status.
2. Fluorescent indicator tube and LEDs are all turned on. Press **FUNCTION** button, the fluorescent indicator tube displays pattern change to cycle. Turning the **VOLUME** knob, and the each LED turned on to order.
3. Press **■** (CD) button, and the Key check mode.
4. The fluorescent indicator tube displays "KEY=0 JOG=0". Each time a button is pressed, "KEY"=value increases. However, once a button is pressed, it is no longer taken into account. "JOG=" value increases like 1, 2, 3... if rotating **VOLUME** knob in clock width, or it decreases like 0, 9, 8... if rotating in counter clock width.
5. To exit from this mode, press order all buttons (15 buttons), the displays "KEY=OK", and press any button, or disconnect the power cord.

SUB CLOCK CHECK

1. Connect an oscilloscope to IC601 pin ⑨ and ground of the MAIN board.
2. Press two buttons **PLAY MODE** and **⊞** (MD) Simultaneously, and the fluorescent indicator tube displays "32.768 kHz (91)".
3. To check the signal on oscilloscope becomes 32 kHz square wave.
4. Press **POWER** button to exit.

TA CHECK

1. Press **POWER** button and system power on.
2. Press two buttons **PLAY MODE** and **■** (CD) simultaneously, the fluorescent indicator tube displays "TA Test".
3. Rotation **VOLUME** knob in clock width a little, the fluorescent indicator tube displays "Volume MAX". Rotation **VOLUME** knob in counter clock width a little, the fluorescent indicator tube displays "Volume MIN".
4. Press **CD-MD SYNC** button, the fluorescent indicator tube displays "BASS/TRE MAX". Press **REPEAT** button, the fluorescent indicator tube displays "BASS/TRE MIN". Press **■** (MD) button, the fluorescent indicator tube displays "ALL FLAT". Press **■** (CD) button, the fluorescent indicator tube displays "SURROUND = ON".
5. Press **POWER** button to exit, and system power off.

SECTION 2 GENERAL

LOCATION OF CNTROLS

– Front Panel –

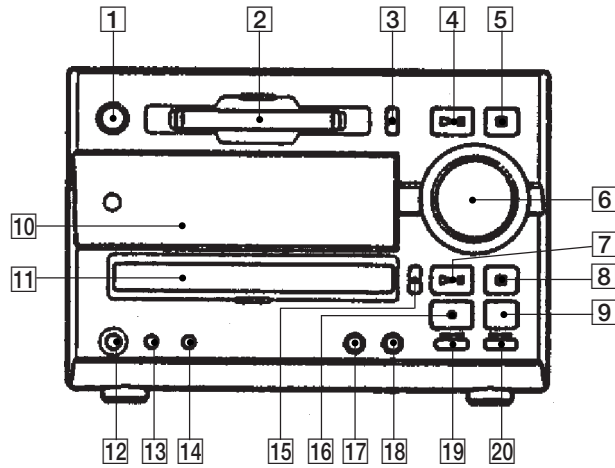

- 1 POWER button
- 2 MD disk slot
- 3 ≡ (MD) button
- 4 ►|| (MD) button
- 5 ■ (MD) button
- 6 VOLUME control knob
- 7 ►|| (CD) button
- 8 ■ (CD) button
- 9 FUNCTION button
- 10 Fluorescent indicator tube
- 11 CD disc tray
- 12 PHONES jack
- 13 PLAY MODE • TUNING MODE button
- 14 REPEAT • STEREO/MONO button
- 15 ≡ (CD) button
- 16 TUNER/BAND button
- 17 CD-MD SYNC button
- 18 ● REC button
- 19 MD/CD ◀◀ ◀◀ • TUNER – button
- 20 MD/CD ▶▶ ▶▶ • TUNER + button

– Rear Panel –

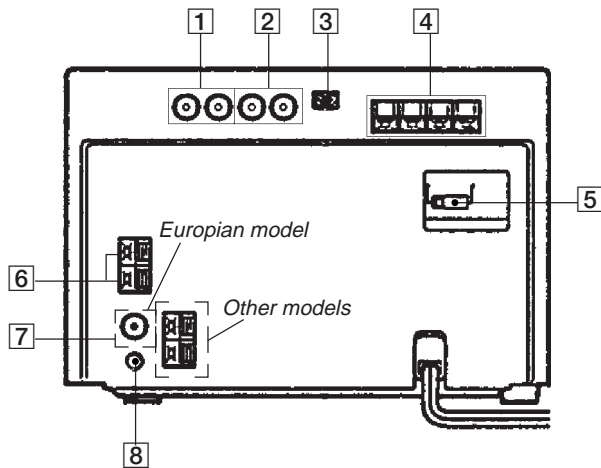

- 1 TAPE OUTPUT pin jack
- 2 TAPE INPUT pin jack
- 3 AU BUS jack
- 4 SPEAKER terminal
- 5 VOLTAGE SELECTOR switch
(Except European models)
- 6 AM ANTENNA terminal
- 7 FM ANTENNA terminal
- 8 SIGNAL GND terminal

– Remote controller –

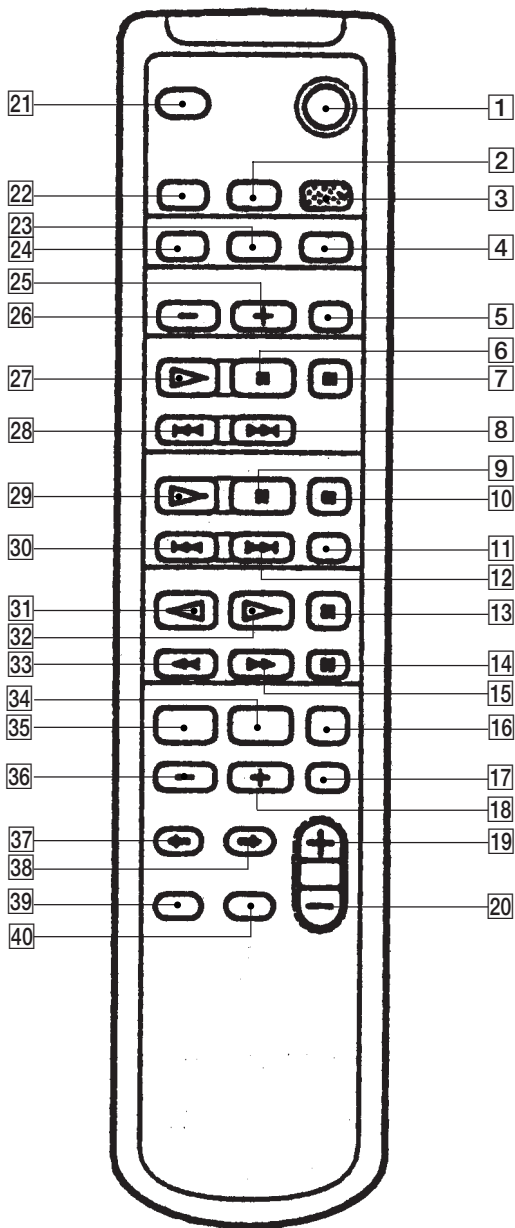

- 1 POWER button
- 2 DBFB button
- 3 MUSIC MENU button
- 4 SCROLL button
- 5 BAND button
- 6 MD button
- 7 MD button
- 8 MD button
- 9 CD button
- 10 CD button
- 11 LOOP button
- 12 CD button
- 13 TAPE button
- 14 TAPE button
- 15 TAPE button
- 16 CLOCK/TIMER SET, button
- 17 DISPLAY button
- 18 + button
- 19 VOL + button
- 20 VOL - button
- 21 SLEEP button
- 22 FUNCTION button
- 23 REPEAT button
- 24 PLAY MODE button
- 25 PRESET + button
- 26 PRESET - button
- 27 MD button
- 28 MD button
- 29 CD button
- 30 CD button
- 31 TAPE button
- 32 TAPE button
- 33 TAPE button
- 34 CLOCK/TIMER SELECT button
- 35 EDIT button
- 36 - button
- 37 CURSOR button
- 38 CURSOR button
- 39 ENTER/YES button
- 40 CANCEL/NO button

Step 2: Setting the time

You can set the time, when you turn off the system power. You must set the time before you can use the timer functions.

The clock is on a 24-hour system for the European model, and a 12-hour system for other models.

The European model is used for illustration purpose.

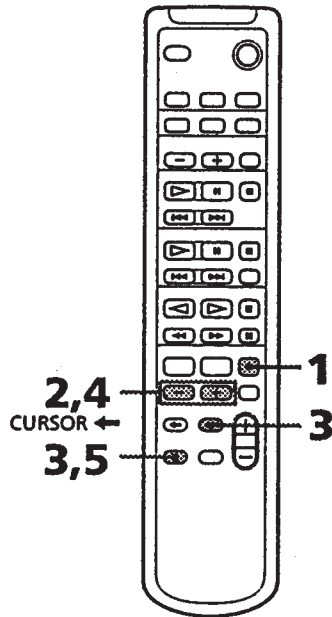

1 Press CLOCK/TIMER SET.
The clock appears and the hour indication flashes.

2 Press +/- to set the hour.



3 Press ENTER/YES or CURSOR →.
The minute indication flashes.



4 Press +/- to set the minute.

5 Press ENTER/YES.
The clock starts.

If you have made a mistake

Press CURSOR ← or → repeatedly so that the incorrect item flashes, then set it again.

To change the preset time

When you turn off the system power, you can change the preset time

- 1 Press CLOCK/TIMER SET.
- 2 Press +/- repeatedly until "CLOCK SET?" appears.
- 3 Press ENTER/YES.
- 4 Repeat steps 2 through 5.

Tips

- The built-in clock shows the time in the display while the power is off.
- The upper dot flashes for the first half of a minute (0 to 29 seconds), and the lower dot flashes for the last half of a minute (30 to 59 seconds).

SECTION 3 DISASSEMBLY

Note: Follow the disassembly procedure in the numerical order given.

CASE

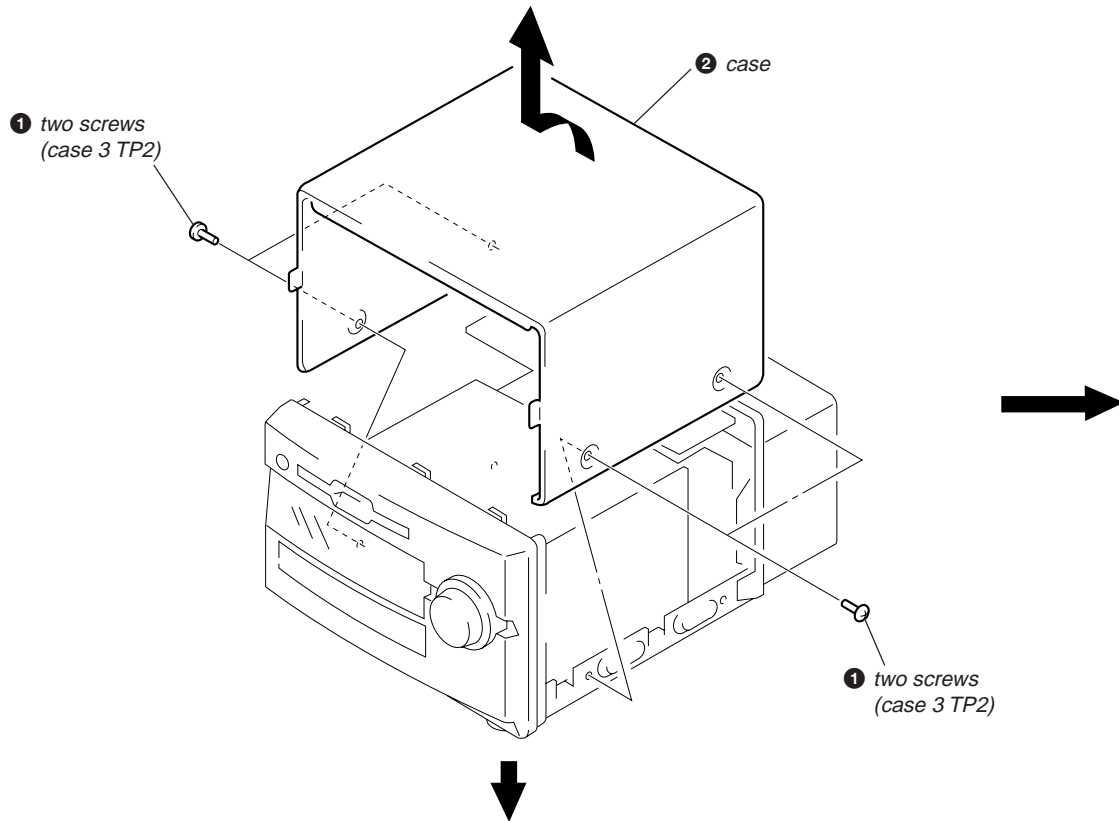

FRONT PANEL/MD MECHANISM DECK SECTION

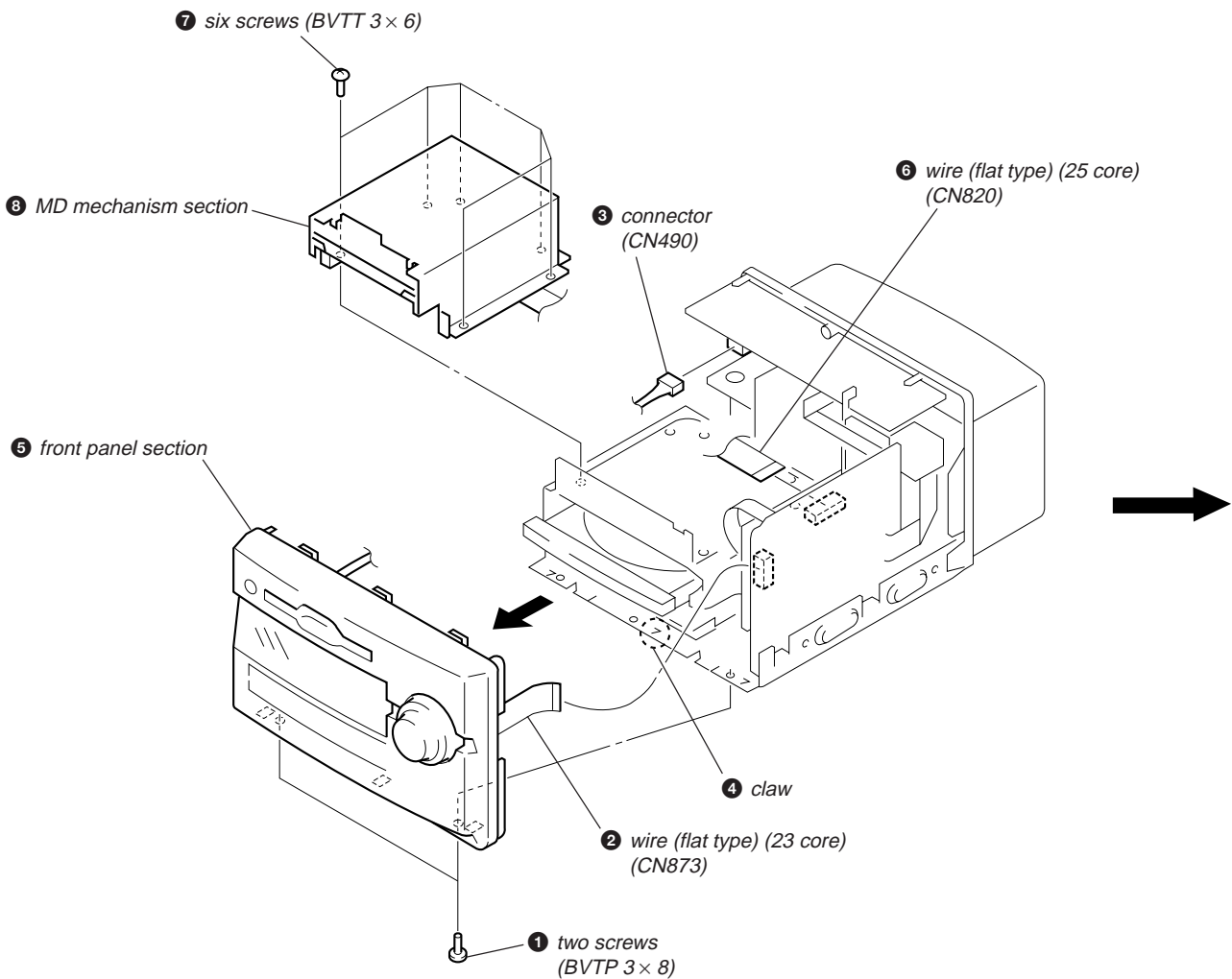

BACK PANEL, JACK BOARD

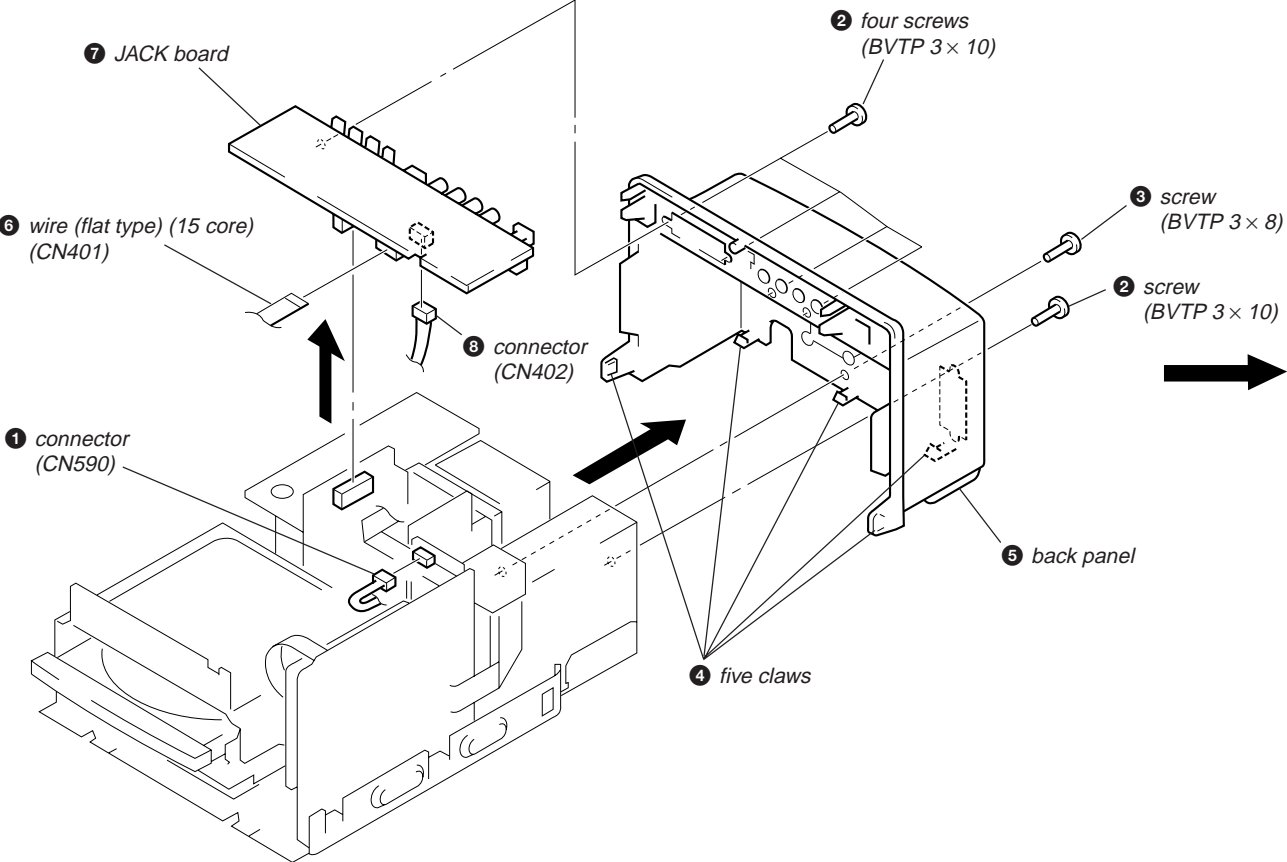

MD MECHANISM DECK (MDM-3D)

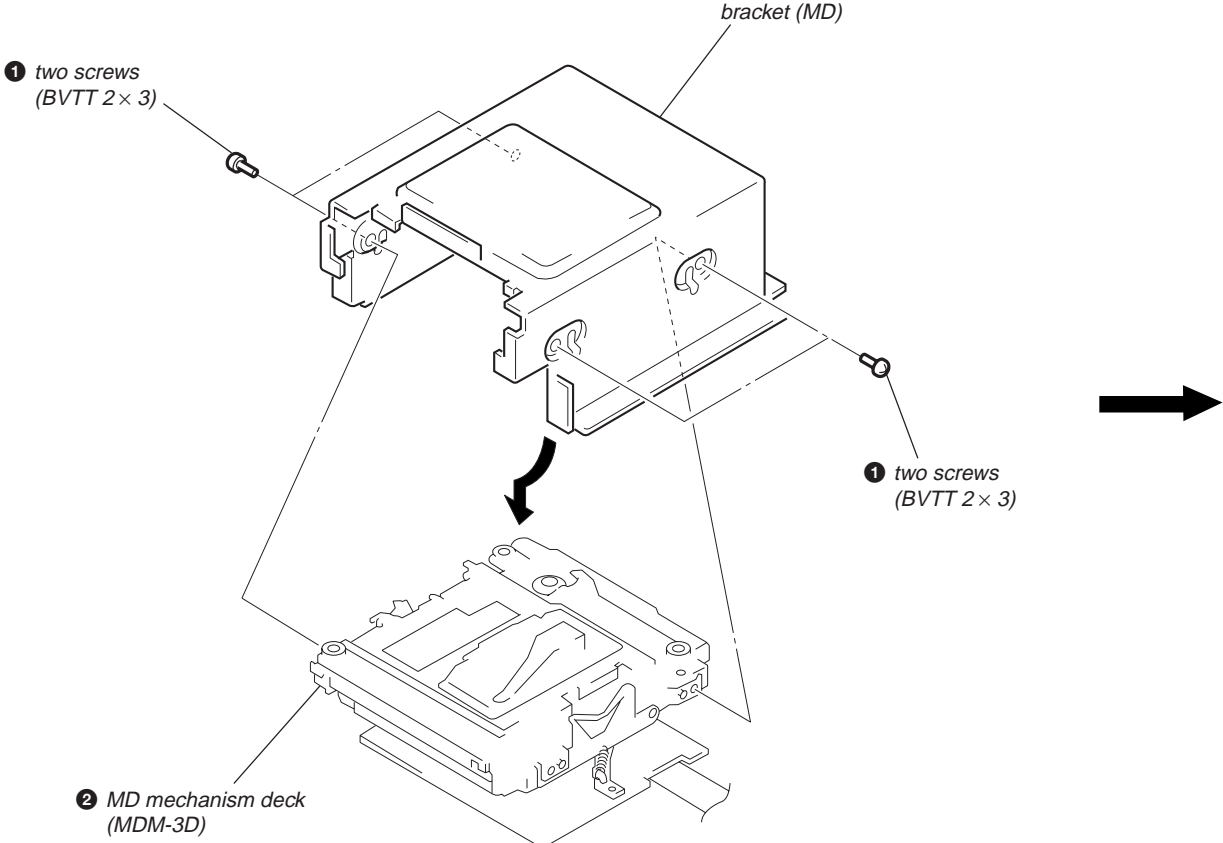

CD MECHANISM DECK (CDM13C-5BD19)

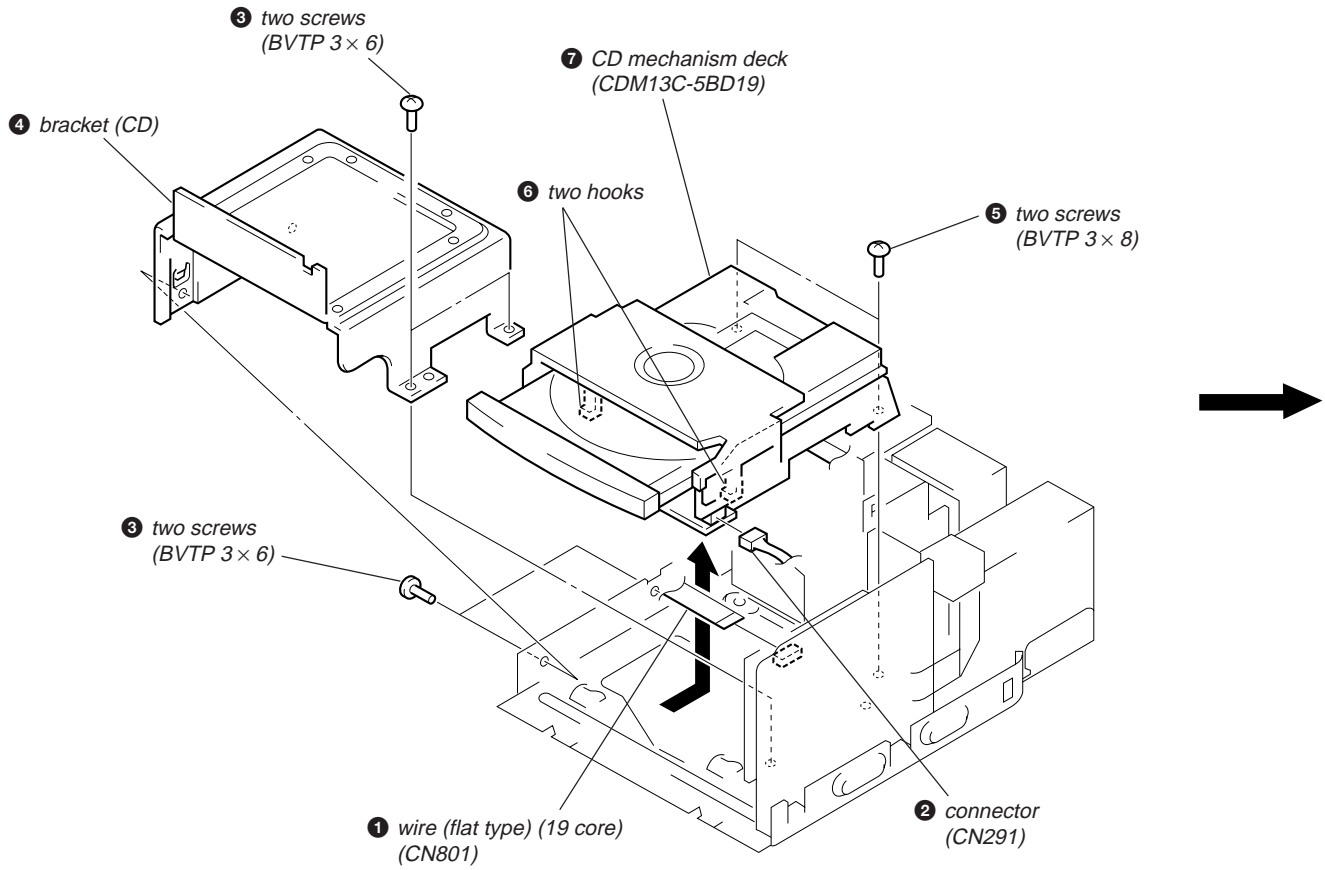

BD (MD) BOARD

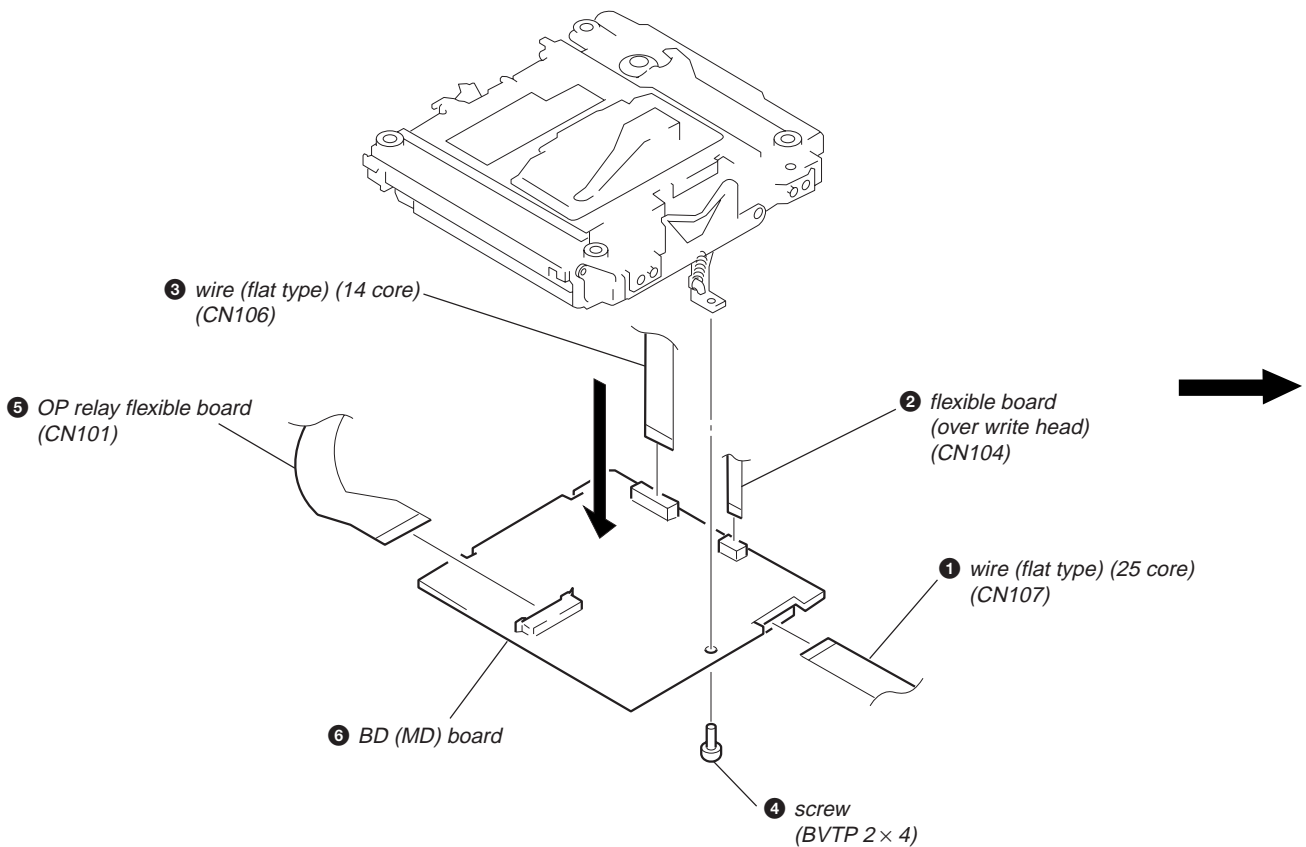

DISC TABLE

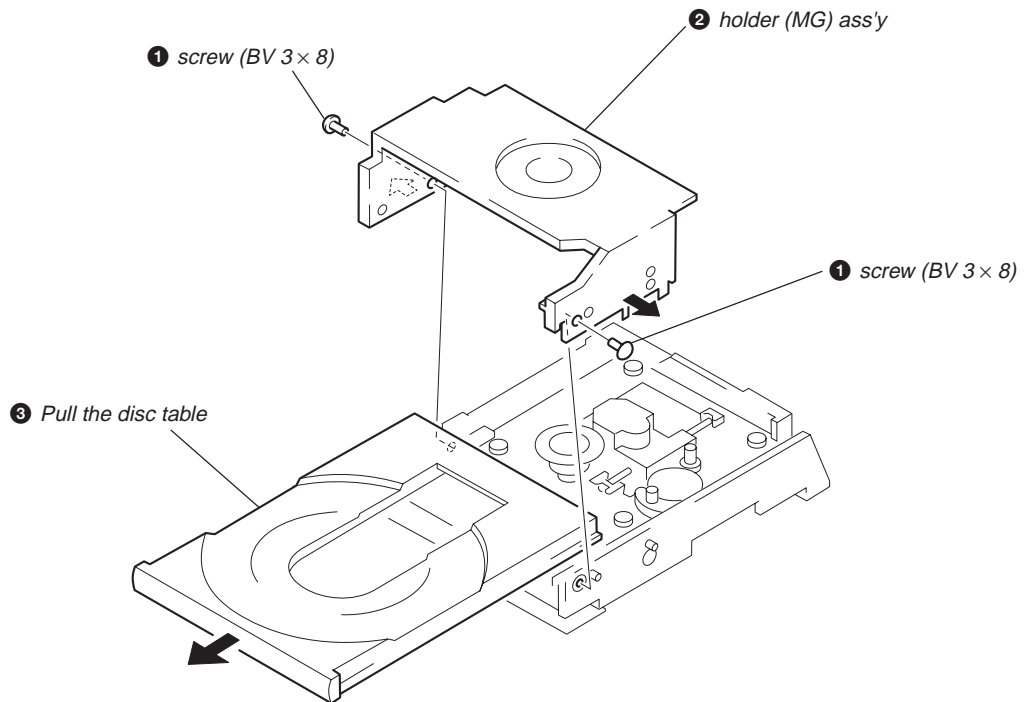

SUB CHASSIS

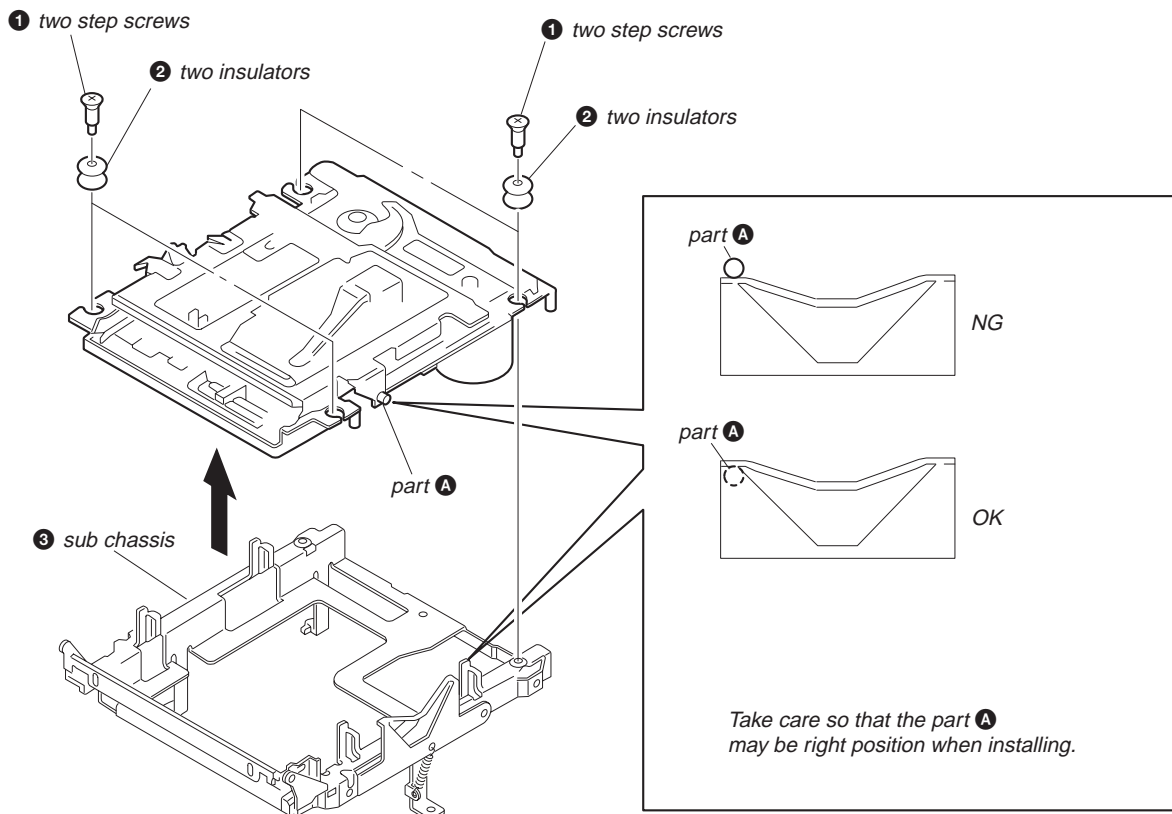

OPTICAL PICK-UP (KSS-213B/K-N)

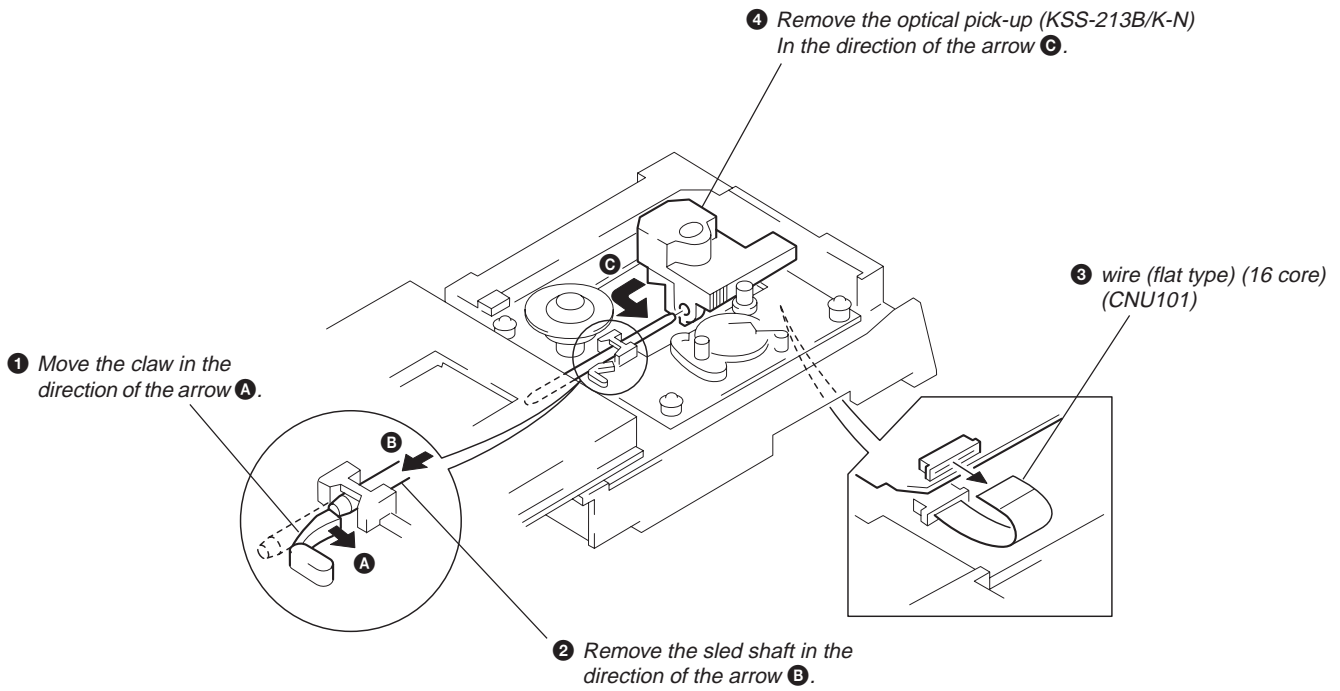

OVER WRITE HEAD

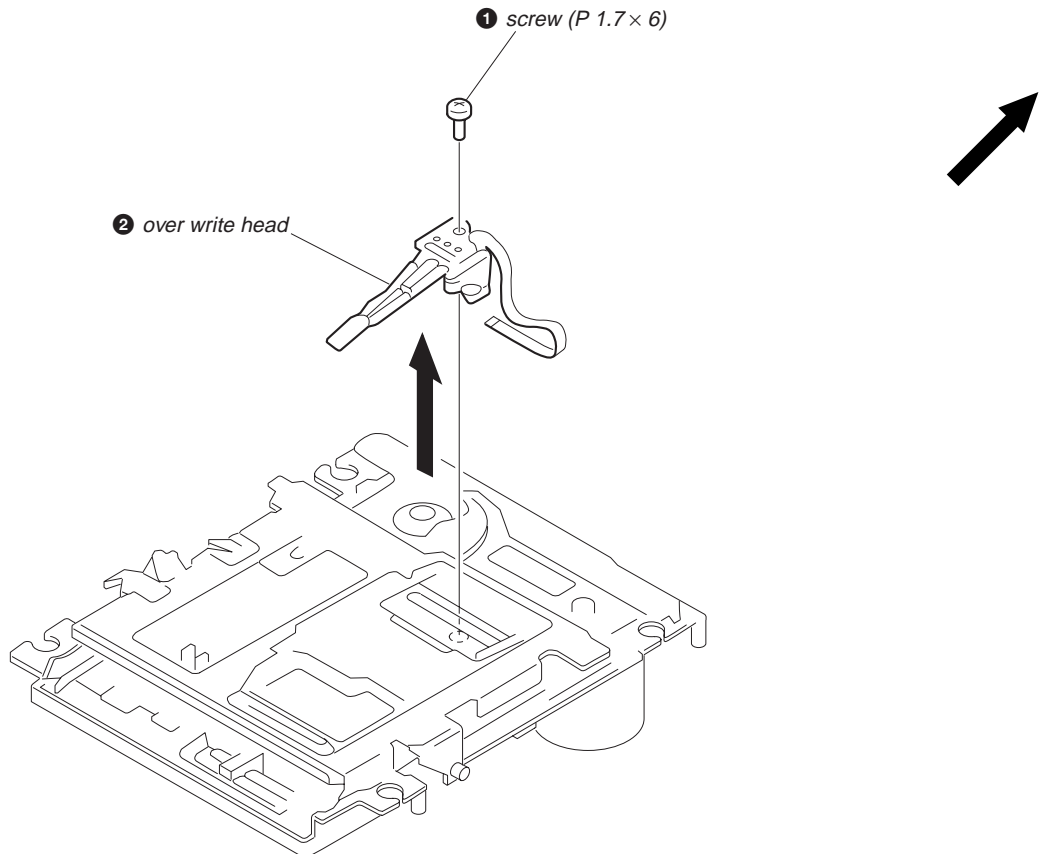

SLIDER COMPLETE ASS'Y

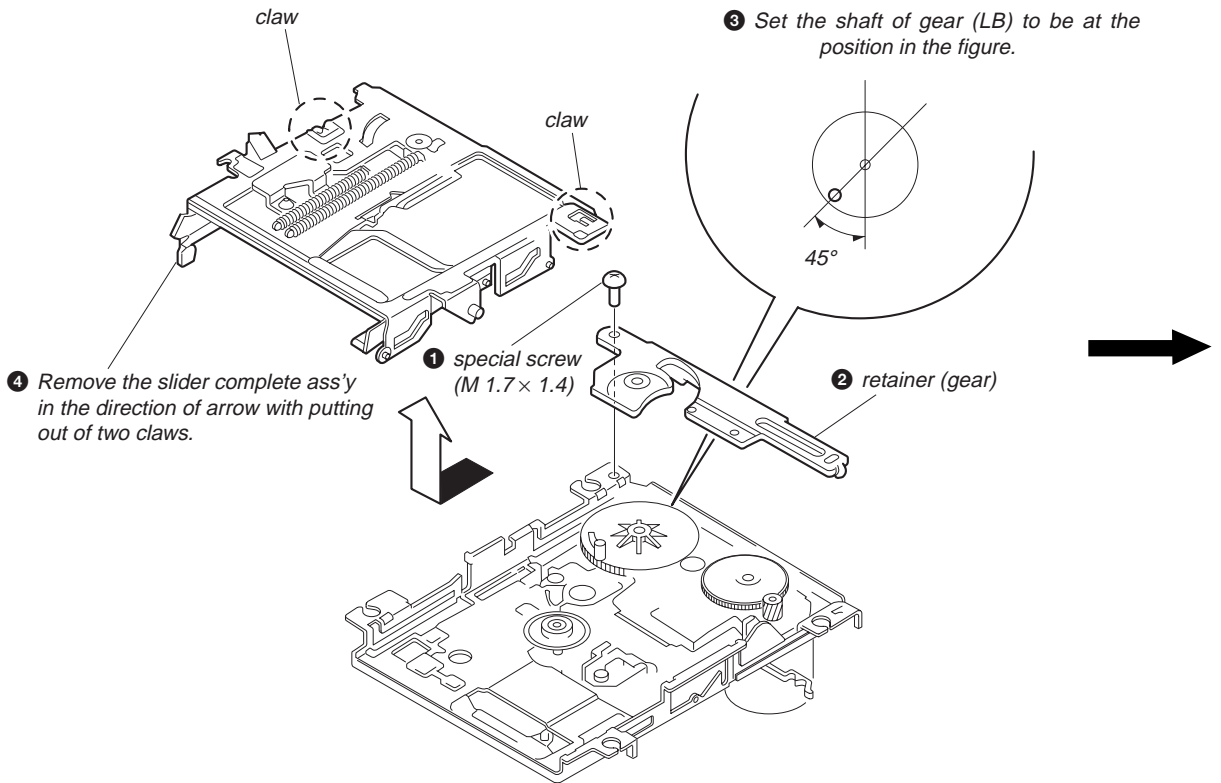

NOTE FOR INSTALLATION

• SLIDER COMPLETE ASS'Y

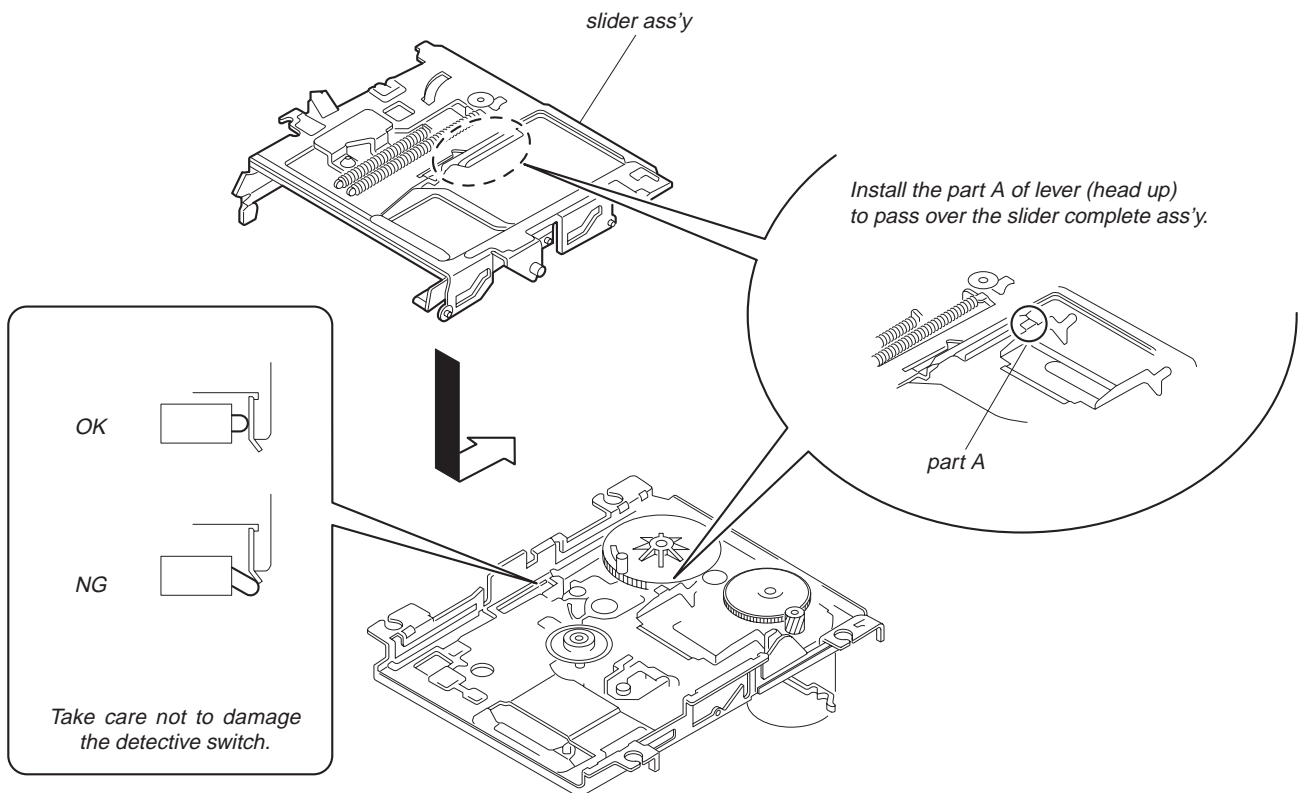



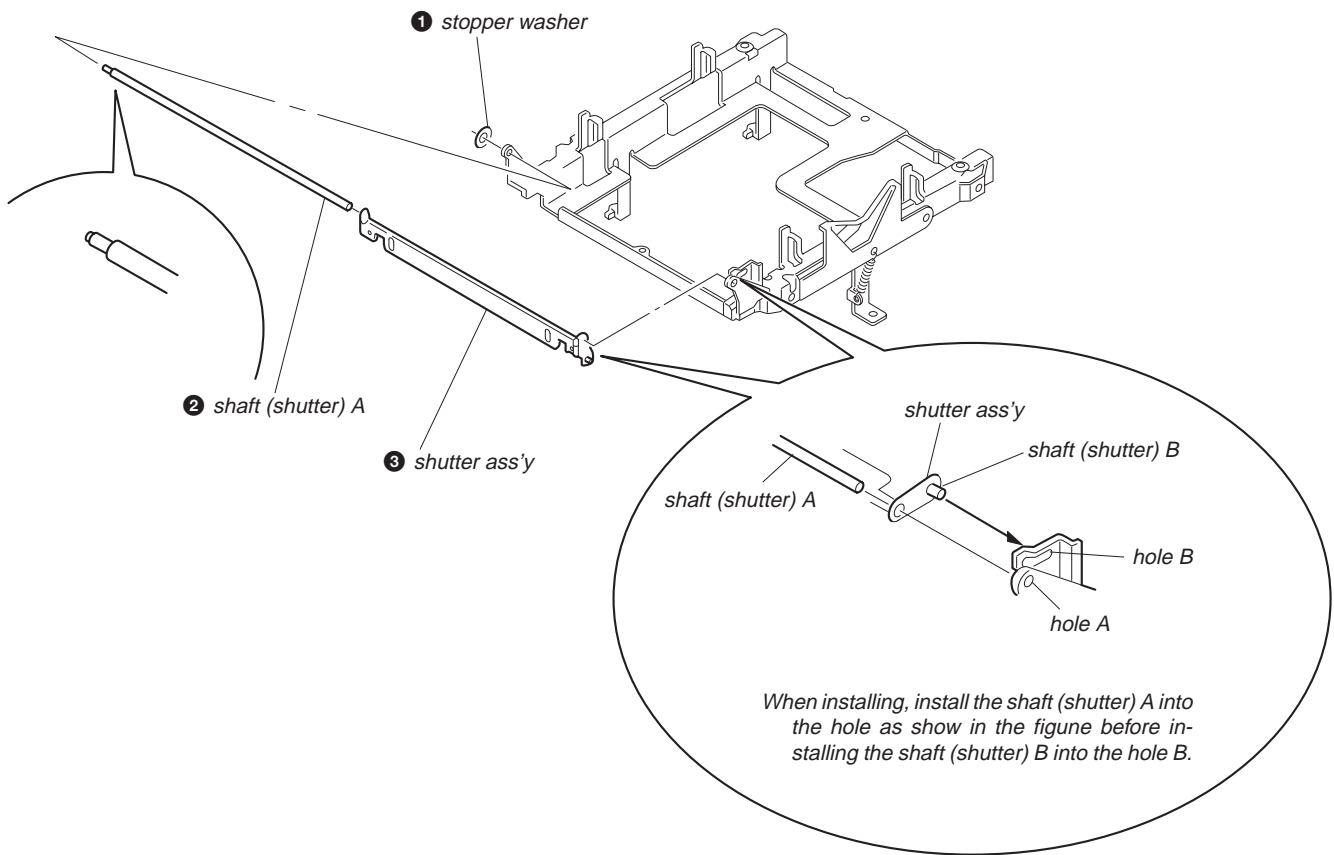

SHUTTER ASS'Y



SECTION 4 TEST MODE



4-1. PRECAUTIONS FOR USE OF TEST MODE

- As loading related operations will be performed regardless of the test mode operations being performed, be sure to check that the disc is stopped before setting and removing it. Even if the  (MD) button is pressed while the disc is rotating during continuous playback, continuous recording, etc., the disc will not stop rotating. Therefore, it will be ejected while rotating. Be sure to press the  (MD) button after pressing the  (CD) button and the rotation of disc is stopped.
- The erasing-protection tab is not detected in the test mode. Therefore, operating in the recording laser emission mode and pressing the  (REC) button, the recorded contents will be erased regardless of the position of the tab. When using a disc that is not to be erased in the test mode, be careful not to enter the continuous recording mode and traverse adjustment mode. But “CREC MODE”, “EF MO CHECK” and “EF MO ADJUST” is detect the erasing-protection tab and recording laser power off.

4-1-1. Recording Laser Emission Mode and Operating Button

- Continuous recording mode (CREC MODE)
- Traverse adjustment mode (EF MO ADJUST)
- Laser power adjustment mode (LDPWR ADJUST)
- Laser power check mode (LDPWR CHECK)
- When pressing the  button.
- Traverse checking mode (EF MO CHECK)

4-2. SETTING THE TEST MODE

With the power supply to the set in OFF (standby) status, while pressing the  button and  (MD) button simultaneously, then release the button.

4-3. RELEASING THE TEST MODE

Press the  button, and the power is turned OFF (standby status), and the set becomes ready for normal operation.

4-4. BASIC OPERATIONS OF THE TEST MODE





All operations are performed using the VOLUME knob button,  (CD) button, and  (CD) button. The functions of these buttons and knob are as follows.

Table 4-1.

Button & Knob	Function
VOLUME knob	Changes parameters and modes.
 (CD) button	Proceeds onto the next step. Finalizes input.
 (CD) button	Returns to previous step. Stops operations.

4-5. SELECTING THE TEST MODE

Thirteen test modes are selected by turn VOLUME.

Table 4-2.



Display	Contents
TEMP CHECK	Temperature compensation offset check
LDPWR CHECK	Laser power check
EF MO CHECK	Traverse (E-F balance) check
EF CD CHECK	Travers (Pre mastered disk) check
FBIAS CHECK	Focus bias check
CPLAY MODE	Continous playback mode
CREC MODE	Continous recording mode
Scurve CHECK	S-curve check (*1)
VERIFY MODE	Non-volatile memory check (*1)
DETRK CHECK	Detrack check
TEMP ADJUST	Temperature compensation offset adjustment
LDPWR ADJUST	Laser power adjustment
EF MO ADJUST	Traverse (E-F balance) adjustment
EF CD ADJUST	Traverse (Pre mastered disk) adjustment
FBIAS ADJUST	Focus bias adjustment
EEP MODE	Non-volatile memory mode (*1)
MANUAL CMD	Manual command transfer mode (*1)
SVDATA READ	Data reading out mode (*1)
ERR DP MODE	Operation of error histories memory
SLED MOVE	Operation of sled moter (*1)
ACCESS MODE	Access check (*1)
0920 CHECK	Outermost periphery check (*1)
WRITE sure?	Non-volatile memory initialize
HEAD ADJUST	HEAD adjustment check (*1)
CPLAY2MODE	Continous playback mode
CREC2MODE	Continous recording mode

- For detailed description of each adjustment mode, refer to the “5. ELECTRICAL ADJUSTMENTS”.
- If a different adjustment mode has been selected by mistake, press the  (CD) button to exit from it.

*1: The EEP MODE, Scurve CHECK, MANUAL CMD VERIFY MODE, SLED MODE, ACCESS MODE, 0920 CHECK, WRITE sure?, HEAD ADJUST and SVDATA READ are not used in servicing. If set accidentally, press the  (CD) button immediately to exit it.

4-6. OPERATING THE CONTINUOUS PLAYBACK MODE

4-6-1. Entering the Continuous Playback Mode



1. Set the disc in the unit. (Whichever recordable discs or discs for playback only are available.)
2. Turn the VOLUME and display “CPLAY MODE”.
3. Press the  (CD) button to change the display to “CPLAY MID”.
4. When access completes, the display changes to “C =  AD= .

Note: The numbers “” displayed show you error rates and ADER.

4-6-2. Changing the Parts to be Played-back

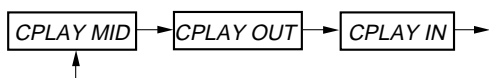

1. Press the  button during continuous playback to change the display as below.





2. When access completes, the display changes to “C1=  AD= .

Note: The numbers “” displayed show you error rates and ADER.

4-6-3. Ending the Continuous Playback Mode



1. Press the  (CD) button. The display will change to “CPLAY MODE”.
2. Press the  (MD) button and remove the disc.

Notes:

1. The playback start address for IN, MID, and OUT are as follows.
IN : 40h cluster
MID : 300h cluster
OUT : 700h cluster
In case you want to display the address of the playback position on the display, press the  (CD) button and display “CPLAY (.
2. The  (CD) button can be used to stop playing anytime.

4-7. OPERATING THE CONTINUOUS RECORDING MODE

4-7-1. Entering the Continuous Recording Mode

1. Set the MO disc in the unit. (Refer to [note 3](#).)
2. Turn the VOLUME and display “CREC MODE”.
3. Press the  (CD) button to change the display to “CREC MID”.
4. When access completes, the display changes to “CREC ()” and **REC** lights up.

Note: The numbers “” displayed shows you the recording position address.

4-7-2. Changing the Parts to be Recorded



1. When the  (CD) button is pressed during continuous recording, the display changes as below. (**REC** indication turns off during change-over of display.)



2. When access completes, the display changes to “CREC ()” and **REC** lights up.

Note: The numbers “” displayed shows you the recording position address.

4-7-3. Ending the Continuous Recording Mode

1. Press the  (CD) button. The display will change to “CREC MODE” and **REC** goes off.
2. Press the  (MD) button and remove the disc.

Notes:

1. The recording start address for IN, MID, and OUT are as follows.
IN : 40h cluster
MID : 300h cluster
OUT : 700h cluster
2. The  (CD) button can be used to stop recording anytime.
3. During the test mode, the erasing-protection tab will not be detected. Therefore be careful not to set the continuous recording mode when a disc not to be erased is set in the unit.
4. Do not perform continuous recording for long periods of time above 5 minutes.
5. During continuous recording, be careful not to apply vibration.

4-8. EEP MODE

This mode reads and writes the contents of the non-volatile memory.

It is not used in servicing. If set accidentally, press the

 (CD) button immediately to exit it.

4-9. ERROR HISTORY MODE

4-9-1. Entering the Error History Mode

1. Turn the VOLUME knob and display “ERR DP MODE”.
2. Press the  (CD) button and display “total rec”.

4-9-2. Ending the Error History Mode.

1. Press the  (CD) button. The display will change to “ERR DP MODE”.

4-9-3. Selecting the Memory to be History

Five memory types are selected by turning the VOLUME knob.

Table 4-3.

No.	Display	Contents	Function
1	total rec	Record time	Total time of laser power high. About 20% of total recording time.
2	total play	playback time	Total time of playback.
3	retry err	Total retry error	Total count of record and playback retry error.
4	total err	All error count	Total count of error.
5	err history	Error history	Error contents display.
* 6	err refresh	Error refresh	Clear the error histories memory

* Error refresh with optical pick-up exchange, another not execute.

4-9-4. Operating the displayed histories.

• Record time

1. Turn the VOLUME knob and display “total rec”.
2. Press the  (CD) button and display “r 0000 h”.

Note • r 0: total time

• Playback time

1. Turn the VOLUME knob and display “total play”.
2. Press the  (CD) button and display “p 0000 h”.

Note • p 0: total time

• Total retry error

1. Turn the VOLUME knob and display “retry err”.
2. Press the  (CD) button and display “r 00 p 00”.

Note • r 00: Record total error
• p 00: Playback total error

• All error count

1. Turn the VOLUME knob and display “total err”.
2. Press the  (CD) button and display “total 00”.

Note • total 00: total error

• Error history

1. Turn the VOLUME knob and display “err history”.
2. Press the  (CD) button and display “00 C 00”.

Note • 0 00: Number of error
• C 00: Error code (See table 4-4.)

4-9-5. Ending the displayed histories

1. Press the  (CD) button, the display will change to memory types.

Table 4-4.

Error Code	Contents	Error Code	Contents
00	No error	05	Out of FOK
01	Disc error PTOC does not read	06	Focus does not work
		07	Retry of record
02	DISC error UTOC does not read	08	Record retry error
		09	Retry of Playback
03	Loading error	0A	Playback retry error
04	Address does not read		

4-10. FUNCTIONS OF OTHER BUTTONS

Table 4-3.

Button	Contents
● REC	Turns recording on/off when pressed during continuous playback.
⏏ (MD)	Disc eject

Note: The erasing-protection tab is not detected during the test mode. Recording will start regardless of the position of the erasing-protection tab when the ● REC button is pressed.

4-11. TEST MODE DISPLAYS

Each time the POWER button is pressed, the display changes in the following order.

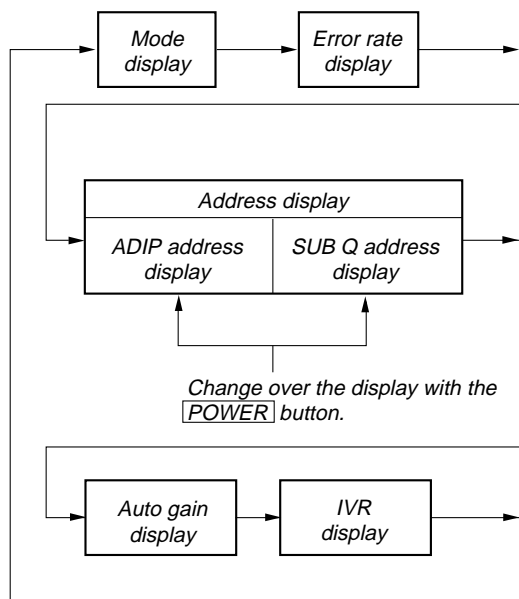

Note: Auto gain display and IVR display are not used in servicing.

1. MODE display
Displays “TEMP ADJUST”, “CPLAY MODE”, etc..

2. Error rate display
Error rates are displayed as follows.
C1= $\square\square\square$ AD= $\square\square$
C1= : Indicates C1 error
AD= : Indicates ADER

3. Address display
Address are displayed as follows.
h= $\square\square\square$ a= $\square\square\square$ (MO groove)
With this display, if POWER button is pressed, the following will be displayed.
h= $\square\square\square$ s= $\square\square\square$ (MO pit and CD)
h=: Header address
s=: SUB Q address
a=: ADIP address

Note: “—” is displayed when the address cannot be read.

4. Auto gain display
Auto gain are displayed as follows.
AG = $\frac{\square\square}{\square\square} [\square\square]$
A B C
A= Focus servo gain coefficient
B= Tracking servo gain coefficient
C= [OK] or [NG] or [- -] (not converged)

4-12. MEANINGS OF OTHER DISPLAYS

Table 4-4.

Display	Contents	
	Light	Off
REC	Recording mode on	Recording mode off
DISC	High reflection rate disc	Low reflection rate disc

SECTION 5 ELECTRICAL ADJUSTMENT

MD SECTION

5-1. PRECAUTIONS FOR CHECKING LASER DIODE EMISSION

To check the emission of the laser diode during adjustments, never view directly from the top as this may lose your eyesight.

5-2. PRECAUTIONS FOR USE OF OPTICAL PICK-UP (KMS-260A)

As the laser diode in the optical pick-up is easily damaged by static electricity, solder the laser tap of the flexible board when using it. Before disconnecting the connector, desolder first. Before connecting the connector, be careful not to remove the solder. Also take adequate measures to prevent damage by static electricity. Handle the flexible board with care as it breaks easily.

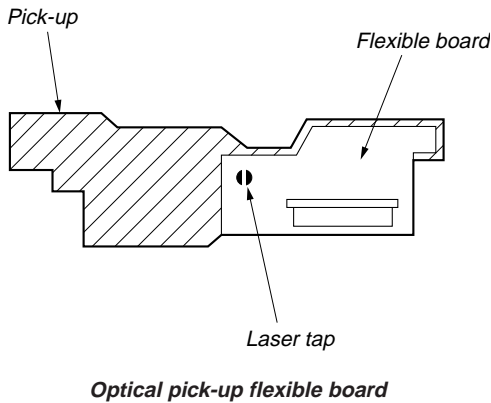

5-3. PRECAUTIONS FOR ADJUSTMENTS

- 1) When replacing the following parts, perform the adjustments and checks with ○ in the order shown in the following table.

Table 5-1.

	Optical Pick-up	BD board		
		IC171	D101	IC101, IC121, IC192
1. Temperature compensation offset adjustment	×	○	○	○
2. Laser power adjustment	○	○	×	○
3. Traverse adjustment	○	○	×	○
4. Focus bias adjustment	○	○	×	○
5. Error rate check	○	○	×	○

- 2) Set the test mode when performing adjustments. After completing the adjustments, exit the test mode.
- 3) Perform the adjustments in the order shown.
- 4) Use the following tools and measuring devices.
 - Check Disc (MD) TDYS-1 (Parts No. 4-963-646-01)
 - Laser power meter LPM-8001 (Parts No. J-2501-046-A)
 - Oscilloscope (Measure after performing CAL of probe.)
 - Digital voltmeter
 - Thermometer
- 5) When observing several signals on the oscilloscope, etc., make sure that VC and ground do not connect inside the oscilloscope. (VC and ground will become short-circuited)

5-4. CREATING MO CONTINUOUSLY RECORDED DISC

* This disc is used in focus bias adjustment and error rate check. The following describes how to create a MO continuous recording disc.

1. Set the test mode.
2. Insert a MO disc (blank disc) commercially available.
3. Turn the VOLUME knob display "CREC MODE".
4. Press the (CD) button and display "CREC MID". "CREC (0300)" is displayed for a moment and recording starts.
5. Complete recording within 5 minutes.
6. Press the (CD) button and stop recording.
7. Press the (MD) button and remove the MO disc.

The above has been how to create a continuous recording data for the focus bias adjustment and error rate check.

Note: Be careful not to apply vibration during continuous recording.

5-5. TEMPERATURE COMPENSATION OFFSET ADJUSTMENT

Save the temperature data at that time in the non-volatile memory as 25 °C reference data.

Notes:

1. Usually, do not perform this adjustment.
2. Perform this adjustment in an ambient temperature of 22 °C to 28 °C. Perform it immediately after the power is turned on when the internal temperature of the unit is the same as the ambient temperature of 22 °C to 28 °C.
3. When D101 has been replaced, perform this adjustment after the temperature of this part has become the ambient temperature.

Adjusting Method:

1. Turn the VOLUME knob and display “TEMP ADJUST”.
2. Press the (CD) button to change the display to “TEMP = ” (The numbers “” displayed shows you the current temperature.)
3. To save the data, press the (CD) button.
When not saving the data, press the (CD) button.
4. When the (CD) button is pressed, “TEMP= SAVE” will be displayed for some time, followed by “TEMP ADJUST”.
When the (CD) button is pressed, “TEMP ADJUST” will be displayed immediately.

Specifications:

The temperature should be within “E0-EF”, “F0-FF”, “00-0F”, “10-1F” and “20-2F”.

5-6. LASER POWER ADJUSTMENT

Connection:

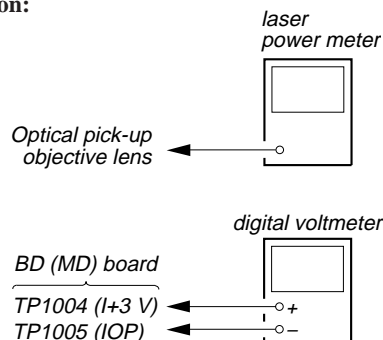

Adjusting Method:

1. Set the laser power meter on the objective lens of the optical pick-up. (When it cannot be set properly, press the button or button and move the optical pick-up.)
Connect the digital voltmeter to TP1004 (I+3 V) and TP1005 (IOP) of the BD (MD) board.
 2. Turn the VOLUME knob and display “LDPWR ADJUST”. (Laser power: for adjustment)
 3. Press the (CD) button and display “LD 0.9 mW \$ ”.
 4. Turn the VOLUME knob so that the reading of the laser power meter becomes 0.82 to 0.91 mW.
Set the range control on the laser power meter to 10 mW, then press the (CD) button to save the adjustment result in the non-volatile memory.
 (“LD SAVE \$ ” will be displayed for a moment.)
 5. Then “LD 7.0 mW \$ ” will be displayed.
 6. Turn the VOLUME knob so that the reading of the laser power meter becomes 6.9 to 7.1 mW, press the (CD) button and save the adjustment result in the nonvolatile memory.
 (“LD SAVE \$ ” will be displayed for a moment.)
- Note:** Do not perform the emission with 7.0 mW more than 15 seconds continuously.
7. Turn the VOLUME knob and display “LDPWR CHECK”.
 8. Press the (CD) button and display “LD 0.9 mW \$ ”.
Check that the reading of the laser power meter becomes 0.80 to 0.96 mW.
 9. Press the (CD) button and display “LD 7.0 mW \$ ”.
Check that the reading of the laser power meter and digital voltmeter satisfy the specified value.

Specification:

Laser power meter reading: 7.0 ± 0.2 mW

Digital voltmeter reading : Optical pick-up displayed value $\pm 10\%$

(Optical pick-up label)

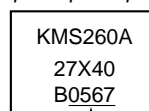

IOP=56.7 mA in this case

$IOP (mA) = \text{Digital voltmeter reading (mV)} / 1 (\Omega)$

10. Press the (CD) button and display “LDPWR CHECK”, and stop the laser emission.
(The (CD) button is effective at all times to stop the laser emission.)

5-7. TRAVERSE (E-F BALANCE) ADJUSTMENT

Note 1: Data will be erased during MO reading if a recorded disc is used in this adjustment.

Note 2: If the traverse waveform is not clear, connect the oscilloscope as shown in the following figure so that it can be seen more clearly.

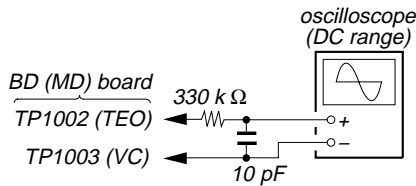

Connection:

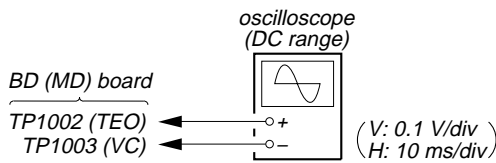

Adjusting Method:

1. Connect an oscilloscope to TP1002 (TEO) and TP1003 (VC) of the BD (MD) board.
2. Load a MO disc (any available on the market). (Refer to note 1.)
3. Press the button or button and move the optical pick-up outside the pit.
4. Turn the VOLUME knob and display "EF MO ADJUST".
5. Press the (CD) button and display "EFB= MO-R". (Laser power READ power/focus servo ON/tracking servo OFF/spindle (S) servo ON)
6. Turn the VOLUME knob so that the waveforms of the oscilloscope becomes the specified value. (When the VOLUME knob is turned, the "" of "EFB= MO-R" changes and the waveform changes.)

In this adjustment, waveform varies at intervals of approx. 2%. Adjust the waveform so that the specified value is satisfied as much as possible.

(MO read power traverse adjustment)

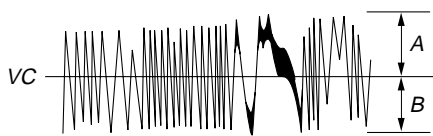

specification: A=B

7. Press the (CD) button, and save the result of adjustment to the non-volatile memory. ("EFB= SAVE" will be displayed for a moment. Then "EFB= MO-W" will be displayed.)

8. Turn the VOLUME knob so that the waveforms of the oscilloscope becomes the specified value. (When the VOLUME knob is turned, the "" of "EFB= MO-W" changes and the waveform changes.)

In this adjustment, waveform varies at intervals of approx. 2%. Adjust the waveform so that the specified value is satisfied as much as possible.

(MO write power traverse adjustment)

(Traverse Waveform)

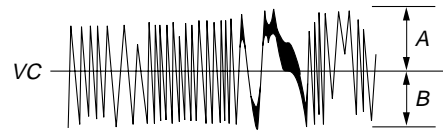

specification: A=B

9. Press the (CD) button, and save the result of adjustment to the non-volatile memory. ("EFB= SAVE" will be displayed for a moment. Then "EFB= MO-P" will be displayed.)

10. The optical pick-up moves to the pit area automatically and servo is imposed.

11. Turn the VOLUME knob until the waveforms of the oscilloscope moves closer to the specified value.

In this adjustment, waveform varies at intervals of approx. 2%. Adjust the waveform so that the specified value is satisfied as much as possible.

(Traverse Waveform)

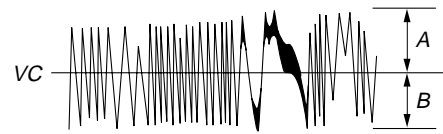

specification: A=B

12. Press the (CD) button, and save the result of adjustment to the non-volatile memory.

("EFB= SAVE" will be displayed for a moment. Then "EFBAL ADJUST" will be displayed.)

The disc stops rotating automatically.

13. Turn the VOLUME knob and display "EF CD ADJUST"

14. Press the (MD) button and remove the MO disc.

15. Load the test disc TDYS-1.

16. Press the (CD) button and display "EFB= CD".

Servo is imposed automatically.

17. Turn the VOLUME knob until the waveforms of the oscilloscope moves closer to the specified value.

In this adjustment, waveform varies at intervals of approx. 2%. Adjust the waveform so that the specified value is satisfied as much as possible.

(Traverse Waveform)

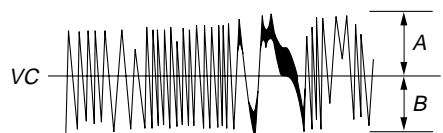

specification: A=B



18. Press the (CD) button, and save the result of adjustment to the non-volatile memory.

("EFB= SAVE" will be displayed for a moment. Then "EFBAL CD" will be displayed.)







19. Press the (MD) button and remove the test disc TDYS-1.

5-8. FOCUS BIAS ADJUSTMENT

Adjusting Method:

1. Load a continuously recorded disc (Refer to “5-4. Creating MO Continuously Recorded Disc”).
2. Turn the VOLUME knob and display “CPLAY MODE”.
3. Press the  (CD) button and display “CPLAY MID”.
4. Press the  button when “C1=0000 AD=00” is displayed.
5. Turn the VOLUME knob and display “FBIAS ADJUST”.
6. Press the  (CD) button and display “0000/00 a=00”.

The first four digits indicate the C1 error rate, the two digits after [/] indicate ADER, and the 2 digits after [a=] indicate the focus bias value.

7. Turn the VOLUME knob in the clockwise direction and find the focus bias value at which the C1 error rate becomes 220. (Refer to note 2.)
8. Press the  (CD) button and display “0000/00 b=00”.
9. Turn the VOLUME knob in the counterclockwise direction and find the focus bias value at which the C1 error rate becomes 220. (Refer to note 2.)
10. Press the  (CD) button and display “0000/00 c=00”.
11. Check that the C1 error rate is below 50 and ADER is 00. Then press the  (CD) button.
12. If the “(00)” in “00-00-00 (00)” is above 20, press the  (CD) button. If below 20, press the  (CD) button and repeat the adjustment from step 2 again.
13. Press the  (CD) button and press the  (MD) button to remove the continuously recorded disc.

Note 1: The relation between the C1 error and focus bias is as shown in the following figure. Find points a and b in the following figure using the above adjustment. The focal point position c is automatically calculated from points a and b.

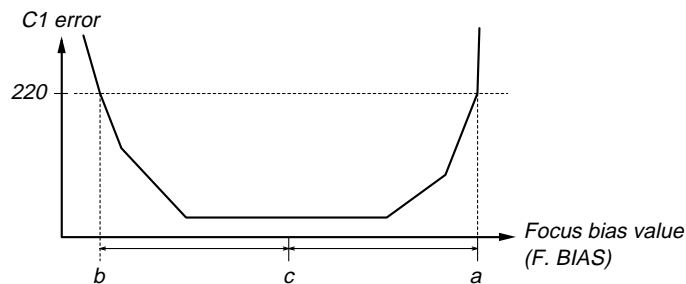

Note 2: As the C1 error rate changes, perform the adjustment using the average value.



5-9. ERROR RATE CHECK



5-9-1. CD Error Rate Check

Checking Method:

1. Load a test disc TDYS-1.
2. Turn the VOLUME knob and display “CPLAY MODE”.
3. Press the  (CD) button and display “CPLAY MID”.
4. “C1= 0000 AD= 00” is displayed.
5. Check that the C1 error is below 20.
6. Press the  (CD) button, stop playback, press the  (MD) EJECT button, and remove the test disc.

5-9-2. MO Error Rate Check







Checking Method:

1. Load a continuously recorded disc (Refer to “5-4. Creating MO Continuously Recorded Disc”).
2. Turn the VOLUME knob and display “CPLAY MODE”.
3. Press the  (CD) button and display “CPLAY MID”.
4. “C1= 0000 AD= 00” is displayed.
5. If the C1 error is below 50, check that ADER is 00.
6. Press the  (CD) button, stop playback, press the  (MD) button, and remove the continuously recorded disc.

5-10. FOCUS BIAS CHECK

Change the focus bias and check the focus tolerance amount.

Checking Method:

1. Load a continuously recorded disc (Refer to “5-4. Creating MO Continuously Recorded Disc”).
2. Turn the VOLUME knob and display “CPLAY MODE”.
3. Press the  (CD) button and display “CPLAY MID”.
4. Press the  button when “C1= 0000 AD= 00” is displayed.
5. Turn the VOLUME knob and display “FBIAS CHECK”.
6. Press the  (CD) button and display “0000/00 c= 00”. The first four digits indicate the C1 error rate, the two digits after [/] indicate ADER, and the 2 digits after [c=] indicate the focus bias value. Check that the C1 error is below 50 and ADER is 00.
7. Press the  (CD) button and display “0000/00 b=00”. Check that the C1 error is not below 220 and ADER is not above 00 every time.
8. Press the  (CD) button and display “0000/00 a= 00”. Check that the C1 error is not below 220 and ADER is not above 00 every time.
9. Press the  (CD) button, next press the  (MD) button, and remove the continuously recorded disc.

Note 1: If the C1 error and ADER are above 00 at points a or b, the focus bias adjustment may not have been carried out properly. Adjust perform the beginning again.

5-11. ADJUSTING POINTS AND CONNECTING POINTS

[BD (MD) BOARD] (SIDE A)

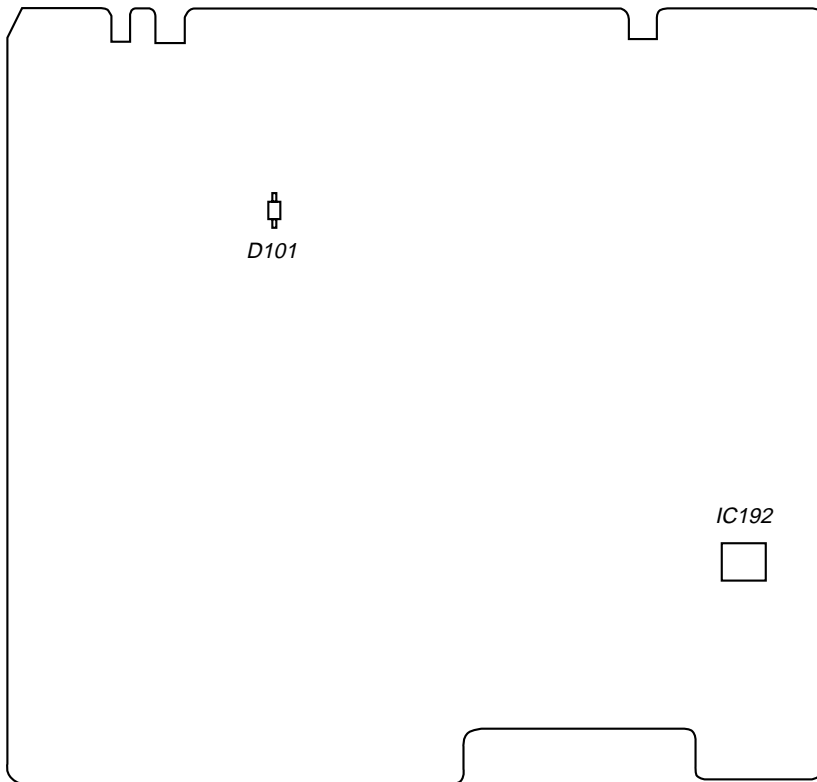

[BD (MD) BOARD] (SIDE B)

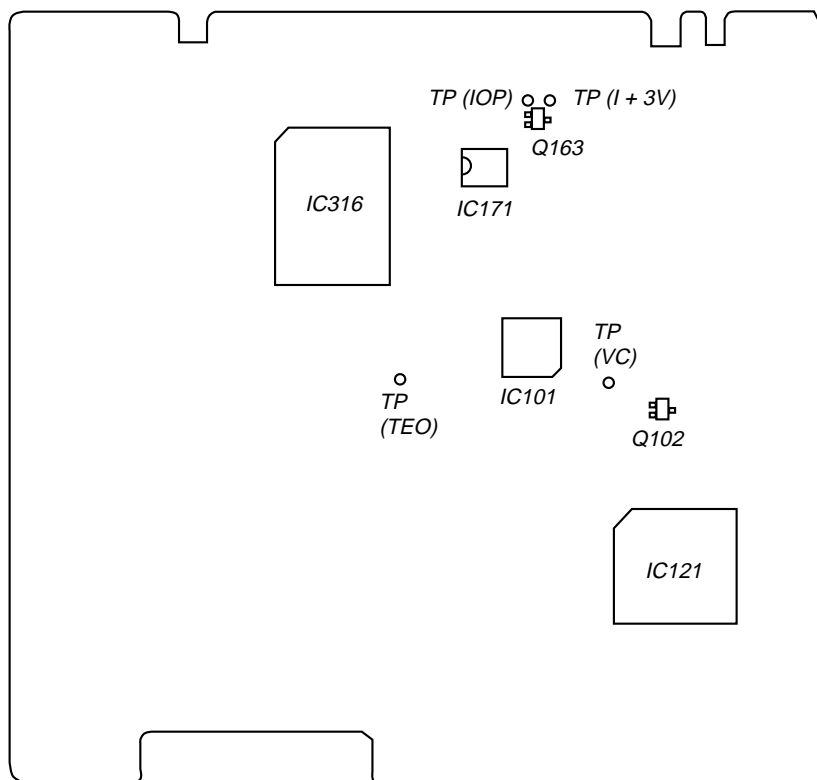

CD SECTION

Notes:

1. CD Block basically constructed to operated without adjustment. Therefore, check each item in order given.
2. Use YEDS-18 disc (Part No.: 3-702-101-01) unless otherwise indicated.
3. Use the oscilloscope with more than 10 MΩ impedance.
4. Clean an object lens by an applicator with neutral detergent when the signal level is low than specified value with the following checks.
5. Adjust the focus bias adjustment when optical pick-up is replaced.

Focus Bias Adjustment

This adjustment is to be done when the optical pick-up is replaced.

Condition: This adjustment is performed with the set placed horizontally.

Connection:

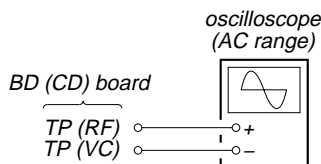

Adjustment Procedure:

1. Connect the oscilloscope to TP (RF) and TP (VC) on BD (CD) board.
2. Turned power switch on. (stop mode)
3. Put disc (YEDS-18) in and press the **▶||** button.
4. Adjust RV101 so that the oscilloscope waveform is as shown in the figure below (eye pattern).
A good eye pattern means that the diamond shape (◇) in the center of the waveform can be clearly distinguished.
5. After adjustment, check the RF signal level.

• RF signal reference waveform (eye pattern)

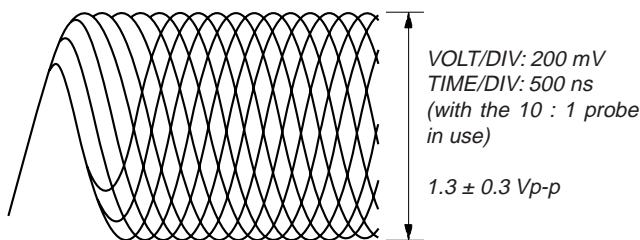

When observing the eye pattern, set the oscilloscope for AC range and raise vertical sensitivity.

S-Curve Check

Connection:

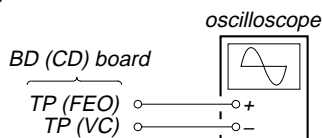

Procedure:

1. Connect the oscilloscope to TP (FEO) and TP (VC) on BD (CD) board.
2. Connect the TP (FOK) and TP (GND) with lead wire.
3. Turned power switch on.
4. Put disc (YEDS-18) in and turned power switch on again and actuate the focus search. (actuate the focus search when disc table is moving in and out.)

5. Confirm that the oscilloscope waveform (S-curve) is symmetrical between A and B. And confirm peak to peak level within $2.4 \pm 0.7 V_{p-p}$.

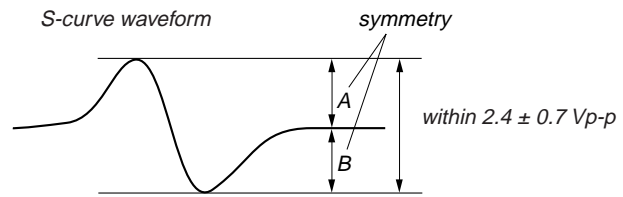

6. After check, remove the lead wire connected in step 2.

Note: • Try to measure several times to make sure that the ratio of A : B or B : A is more than 10 : 7.

- Take sweep time as long as possible and light up the brightness to obtain best waveform.

RF Level Check

Connection:

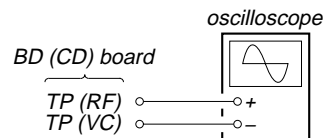

Procedure:

1. Connect the oscilloscope to TP (RF) and TP (VC) on BD (CD) board.
2. Turned power switch on. (stop mode)
3. Put disc (YEDS-18) in and press the **▶||** button.
4. Confirm that oscilloscope waveform is clear and check RF signal level is correct or not.

Note: Clear RF signal waveform means that the shape “◇” can be clearly distinguished at the center of the waveform.

RF signal waveform

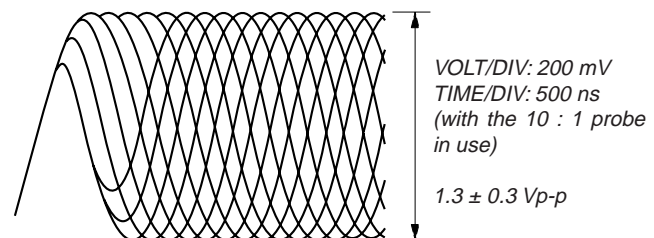

E-F Balance (Traverse) Check

Connection:

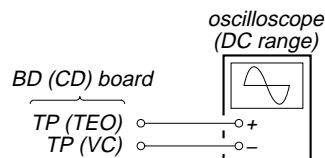

Procedure:

1. Connect the TP100 (ADJ) and Ground with lead wire. (on the MAIN board)
2. Connect the oscilloscope to TP (TEO) and TP (VC) on BD (CD) board.
3. Turned power switch on.
4. Put disc (YEDS-18) in and press the **▶||** button.
5. Press the **TIME** button. (Tracking servo and sled servo are turned off.)
6. Confirm that the oscilloscope waveform is symmetrical on the top and bottom in relation to 0 Vdc, and check this level.

Traverse waveform

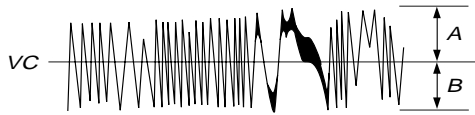

specification: $A=B$

level: $300 \pm 100 \text{ mVp-p}$

specified value: $\bullet \frac{A-B}{2(A+B)} \times 100 = \text{less than } \pm 7\%$
 $\bullet A+B = 300 \pm 100 \text{ mVp-p}$

7. After check, remove the lead wire connected in step 1.

Focus/Tracking Gain Adjustment (RV102, RV103)

This gain has a margin, so even if it is slightly off. There is no problem.

Therefore, do not perform, this adjustment.

Please note that it should be fixed to mechanical center position when you moved and do not know original position.

Adjustment Location :

[BD (CD) BOARD] – Side B –

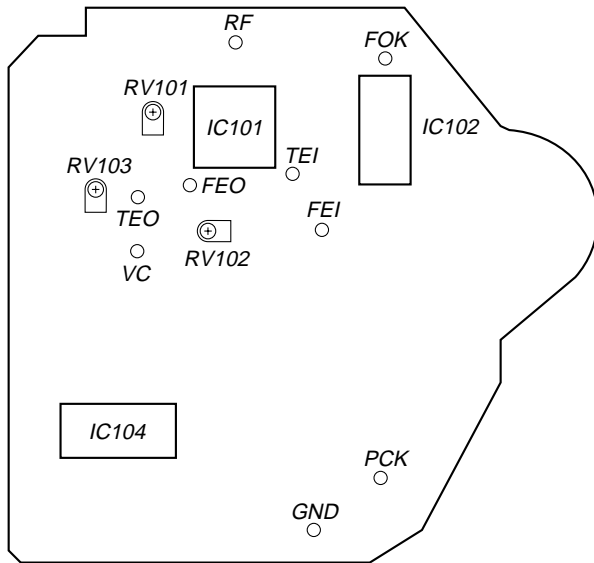

[MAIN BOARD] (1/3) – Conductor Side –

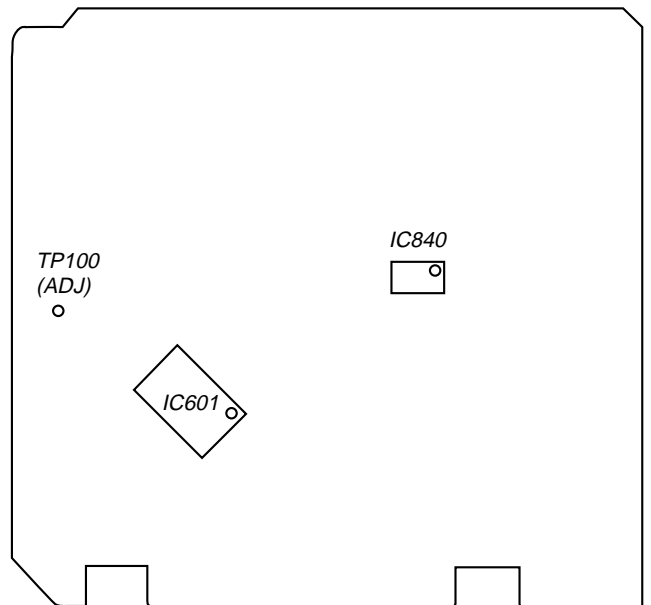

SECTION 6 DIAGRAMS

• Circuit Boards Location

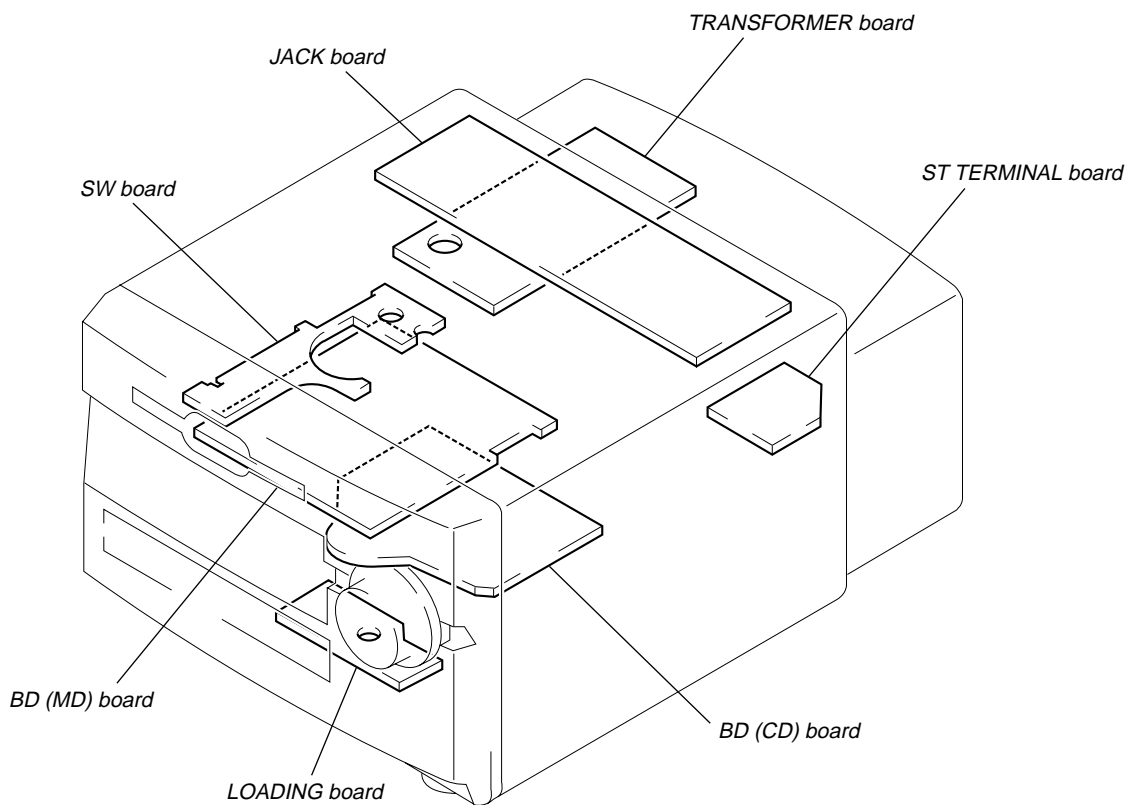
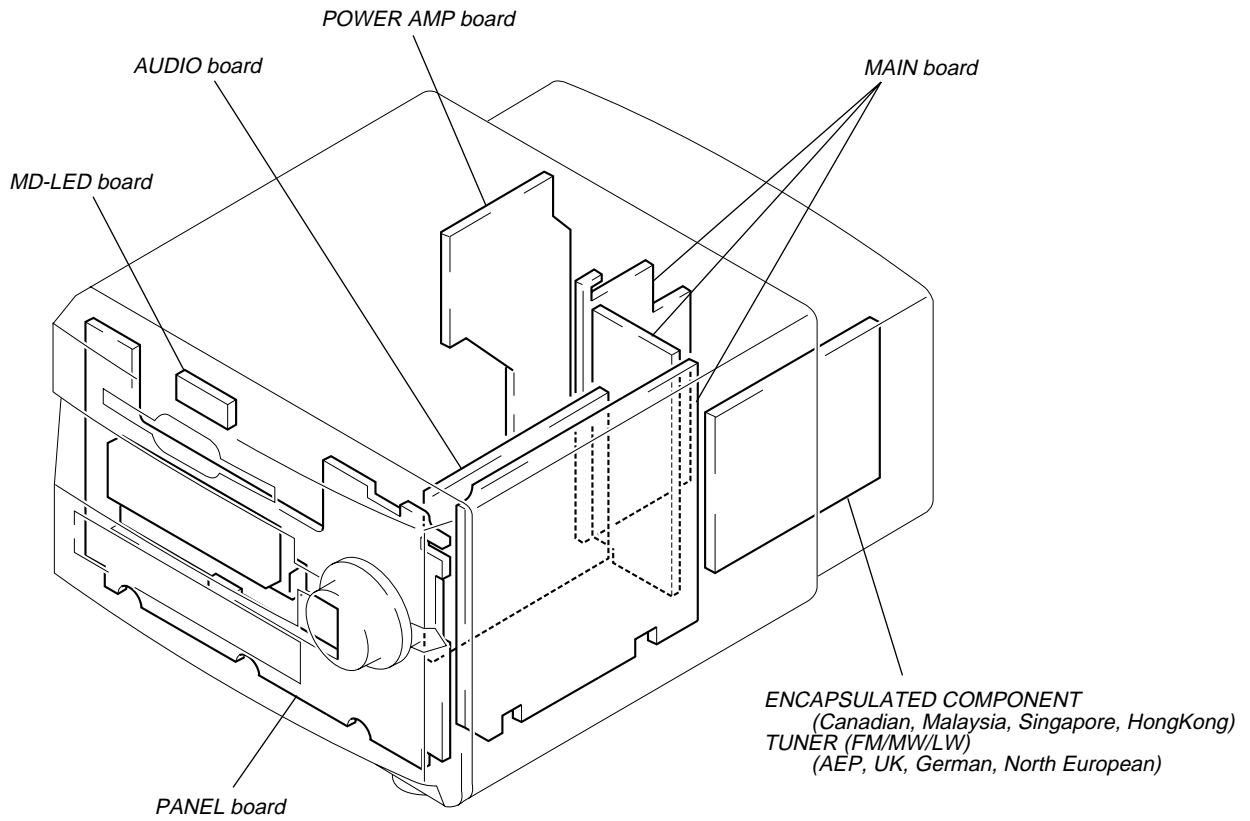

6-1. BLOCK DIAGRAM
- CD Section -

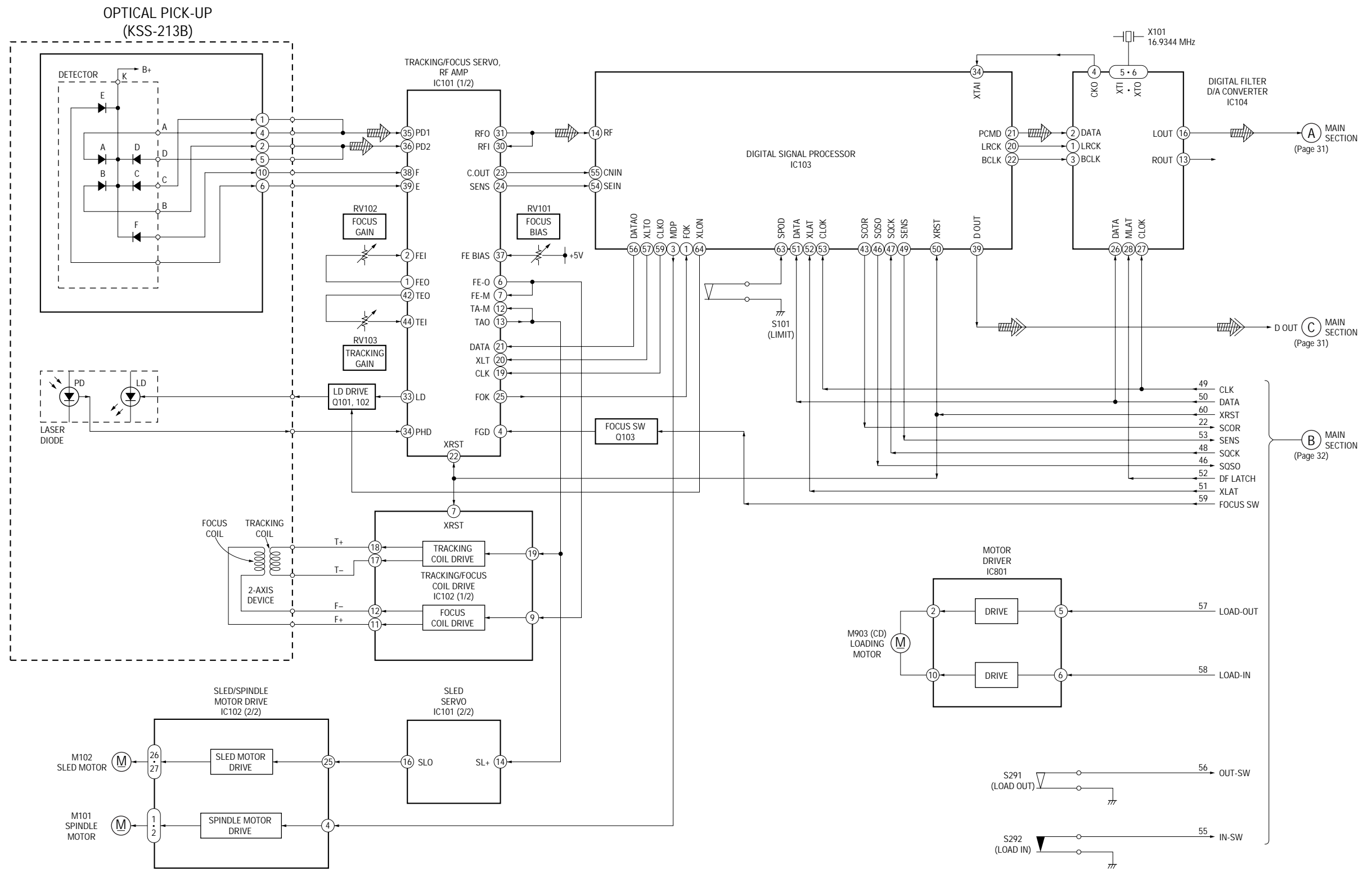

05

– MD Section –

• SIGNAL PATH
 → : PB
 ▨ : REC
 ▨ : digital out (CD)

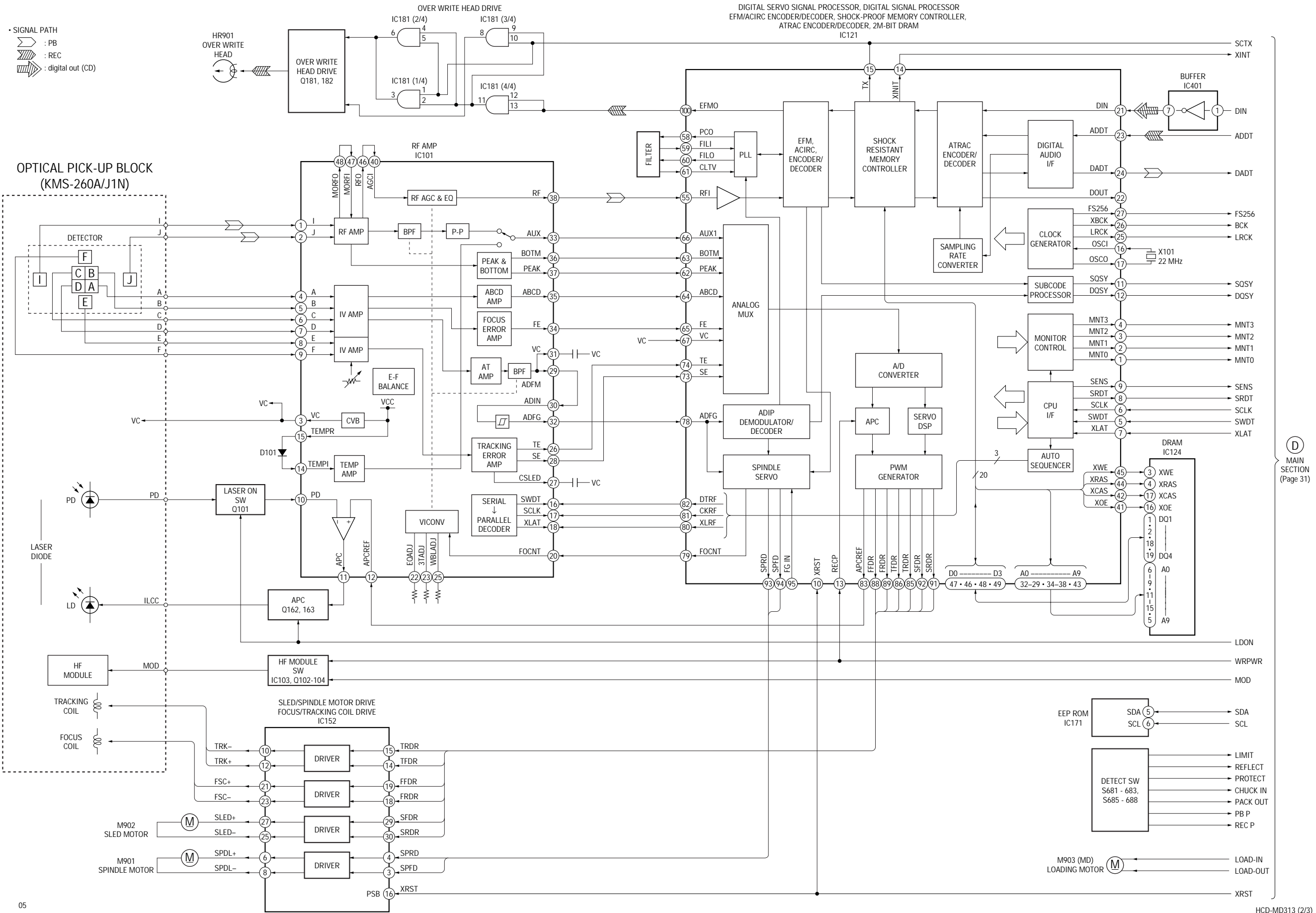

Ⓓ MAIN SECTION (Page 31)

- MAIN Section -

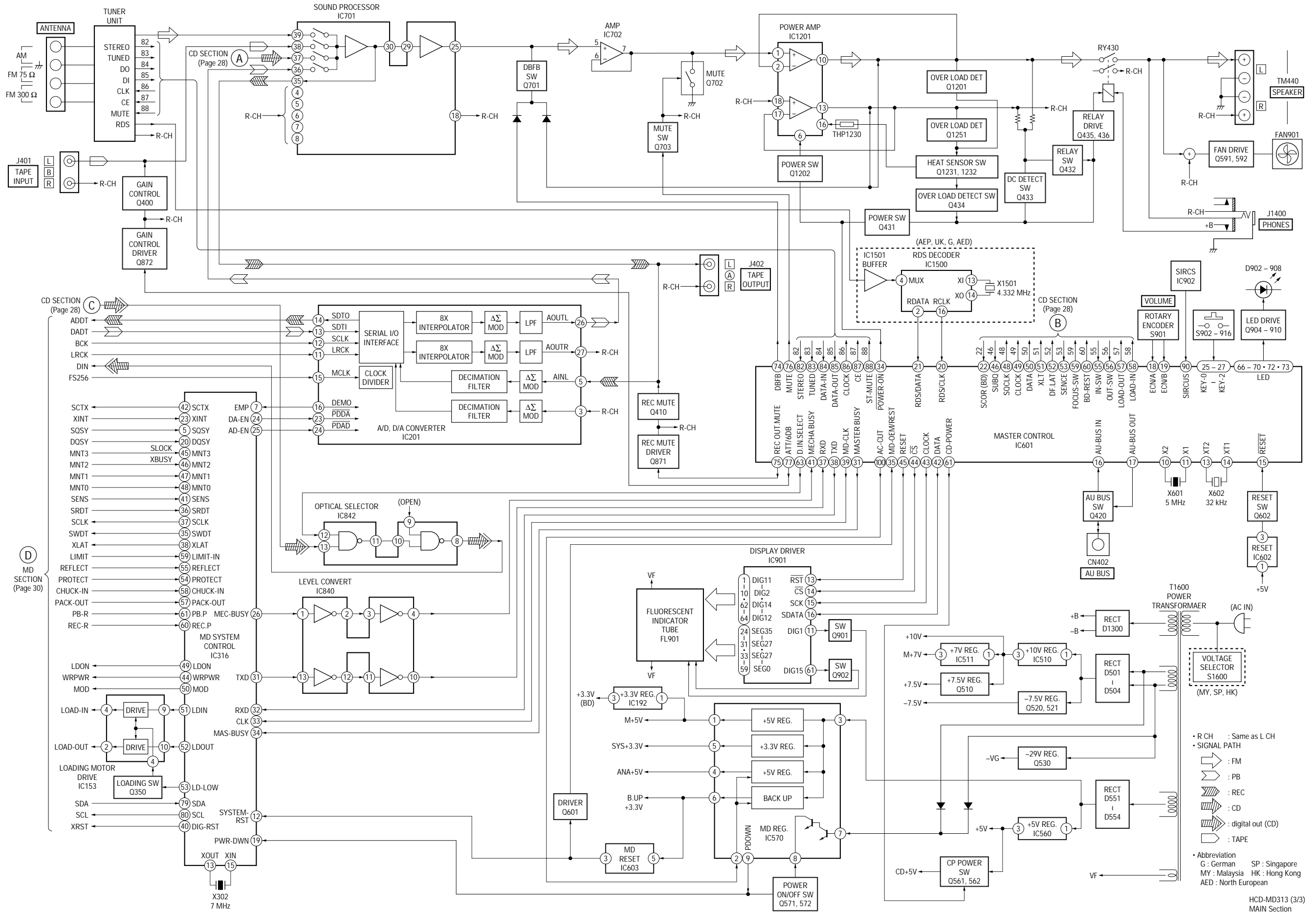

• R CH : Same as L CH
 • SIGNAL PATH
 → : FM
 ⇨ : PB
 ⇨ : REC
 ⇨ : CD
 ⇨ : digital out (CD)
 ⇨ : TAPE

• Abbreviation
 G : German SP : Singapore
 MY : Malaysia HK : Hong Kong
 AED : North European

6-2. PRINTED WIRING BOARD -CD Section -
 • See page 26 for Circuit Boards Location.

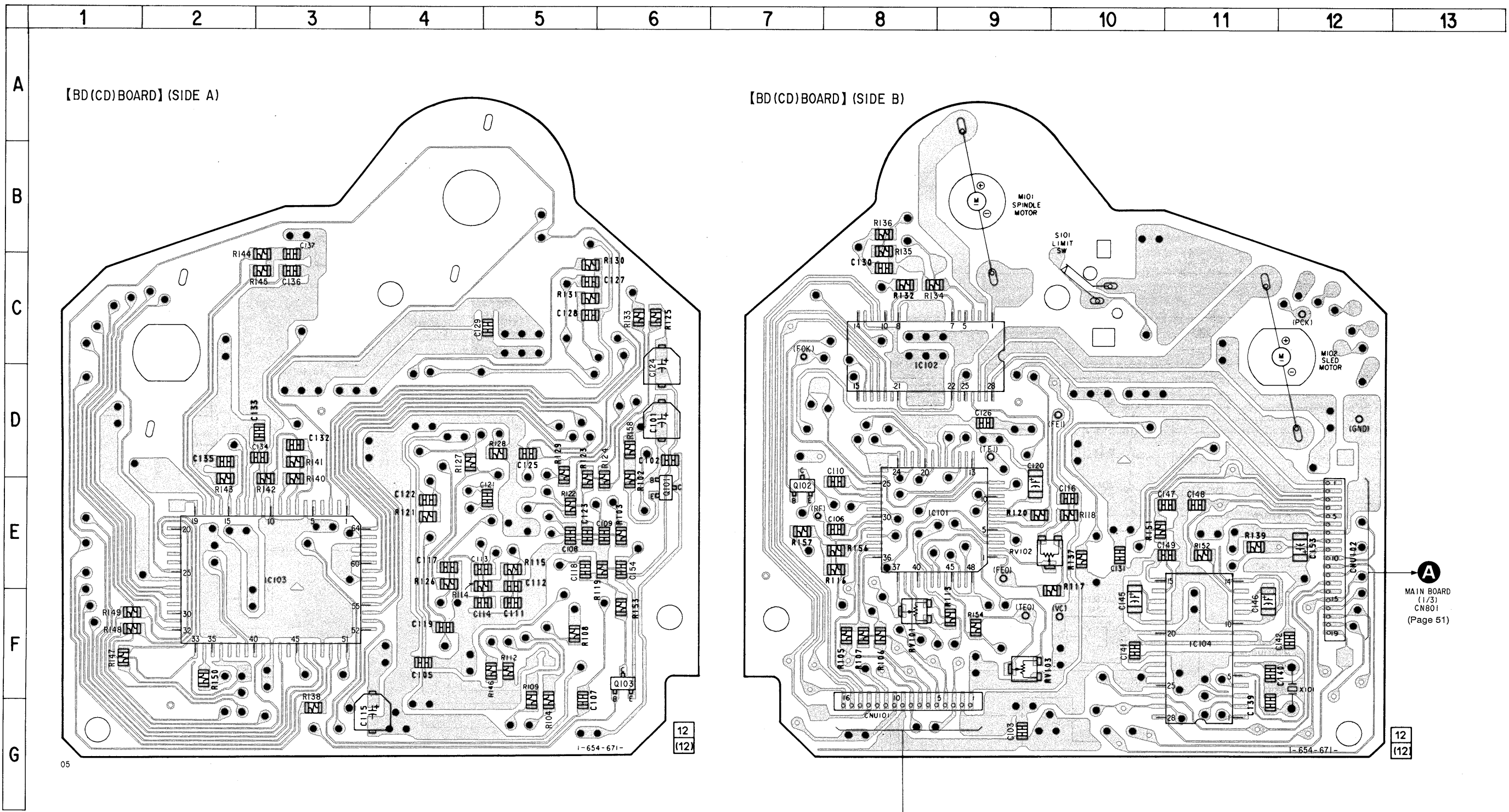

• Semiconductor Location

Ref. No.	Location
IC101	E-9
IC102	C-8
IC103	E-3
IC104	F-11
Q101	E-6
Q102	E-7
Q103	F-6

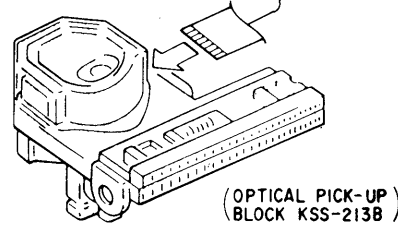

Note on Printed Wiring Board:
 • ○ : parts extracted from the component side.
 • ● : Through hole.
 • [Pattern] : Pattern from the side which enables seeing.
 (The other layers' patterns are not indicated.)

Caution:
 Pattern face side: Parts on the pattern face side seen from the pattern face side are indicated.
 Parts face side: Parts on the parts face side seen from the parts face are indicated.

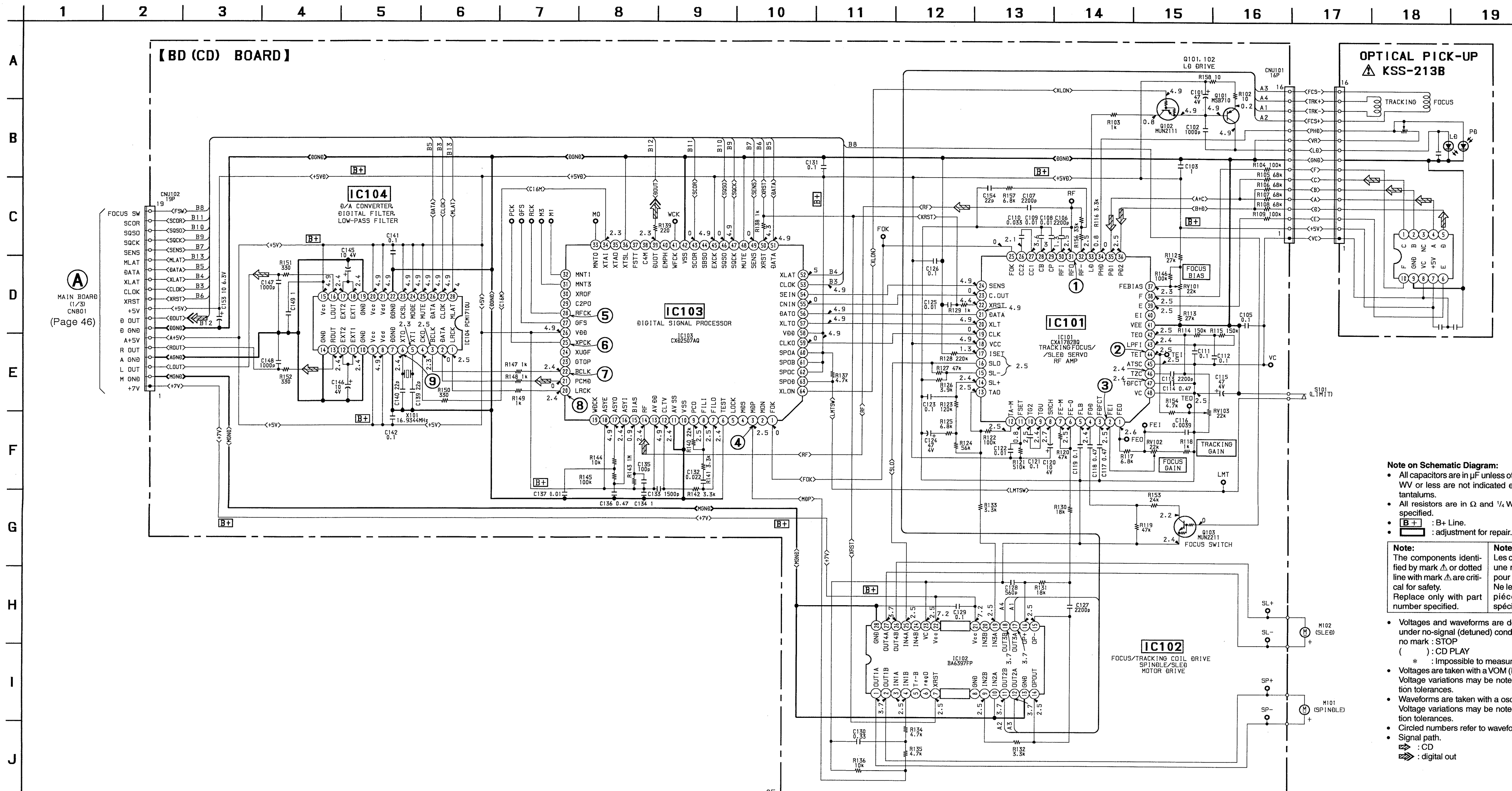

Note on Schematic Diagram:

- All capacitors are in μF unless otherwise noted. pF : μF 50 WV or less are not indicated except for electrolytics and tantalums.
- All resistors are in Ω and $1/4\text{W}$ or less unless otherwise specified.
- **B+** : B+ Line.
- Δ : adjustment for repair.

Note:
The components identified by mark Δ or dotted line with mark Δ are critical for safety. Replace only with part number specified.

Note:
Les composants identifiés par une marque Δ sont critiques pour la sécurité. Ne les remplacer que par une pièce portant le numéro spécifié.

- Voltages and waveforms are dc with respect to ground under no-signal (detuned) conditions.
- no mark : STOP
- () : CD PLAY
- * : Impossible to measure
- Voltages are taken with a VOM (input impedance $10\text{M}\Omega$). Voltage variations may be noted due to normal production tolerances.
- Waveforms are taken with an oscilloscope. Voltage variations may be noted due to normal production tolerances.
- Circled numbers refer to waveforms.
- Signal path.
- \Rightarrow : CD
- \Rightarrow : digital out

6-4. PRINTED WIRING BOARDS – MD Section –
 • See page 26 for Circuit Boards Location.

• Semiconductor Location

Ref. No.	Location
D101	B-4
D181	C-10
D183	C-9
IC101	C-13
IC103	C-14
IC121	E-14
IC124	F-14
IC152	B-14
IC153	B-9
IC171	B-12
IC181	D-9
IC192	E-7
IC201	F-12
IC316	B-11
IC401	F-8
Q101	B-13
Q102	D-14
Q104	C-14
Q104	C-14
Q162	B-13
Q163	B-13
Q181	C-10
Q182	C-9
Q350	B-10

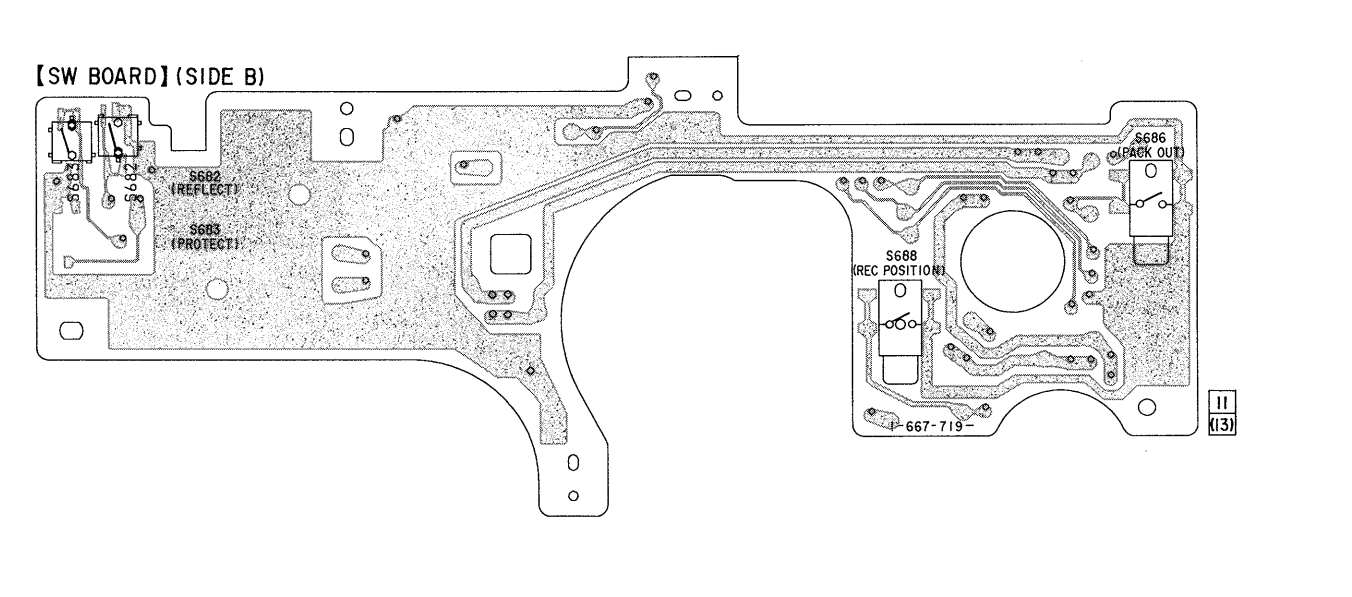
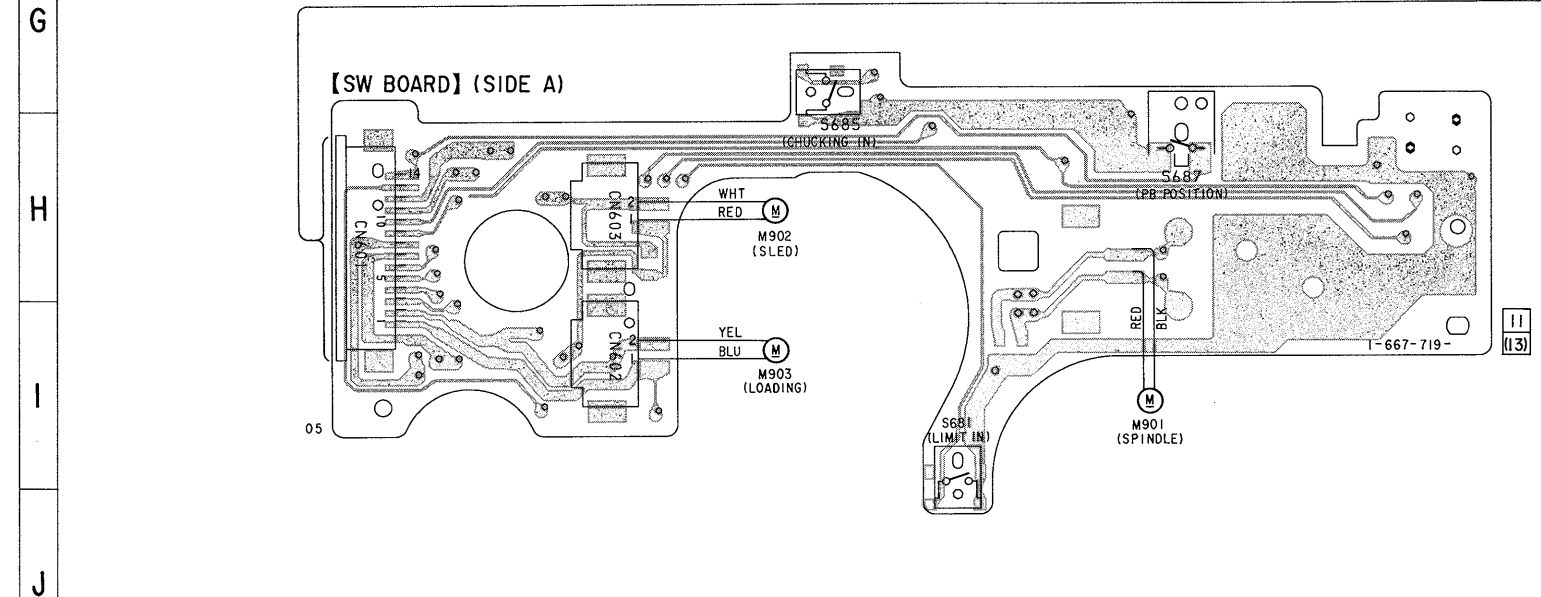
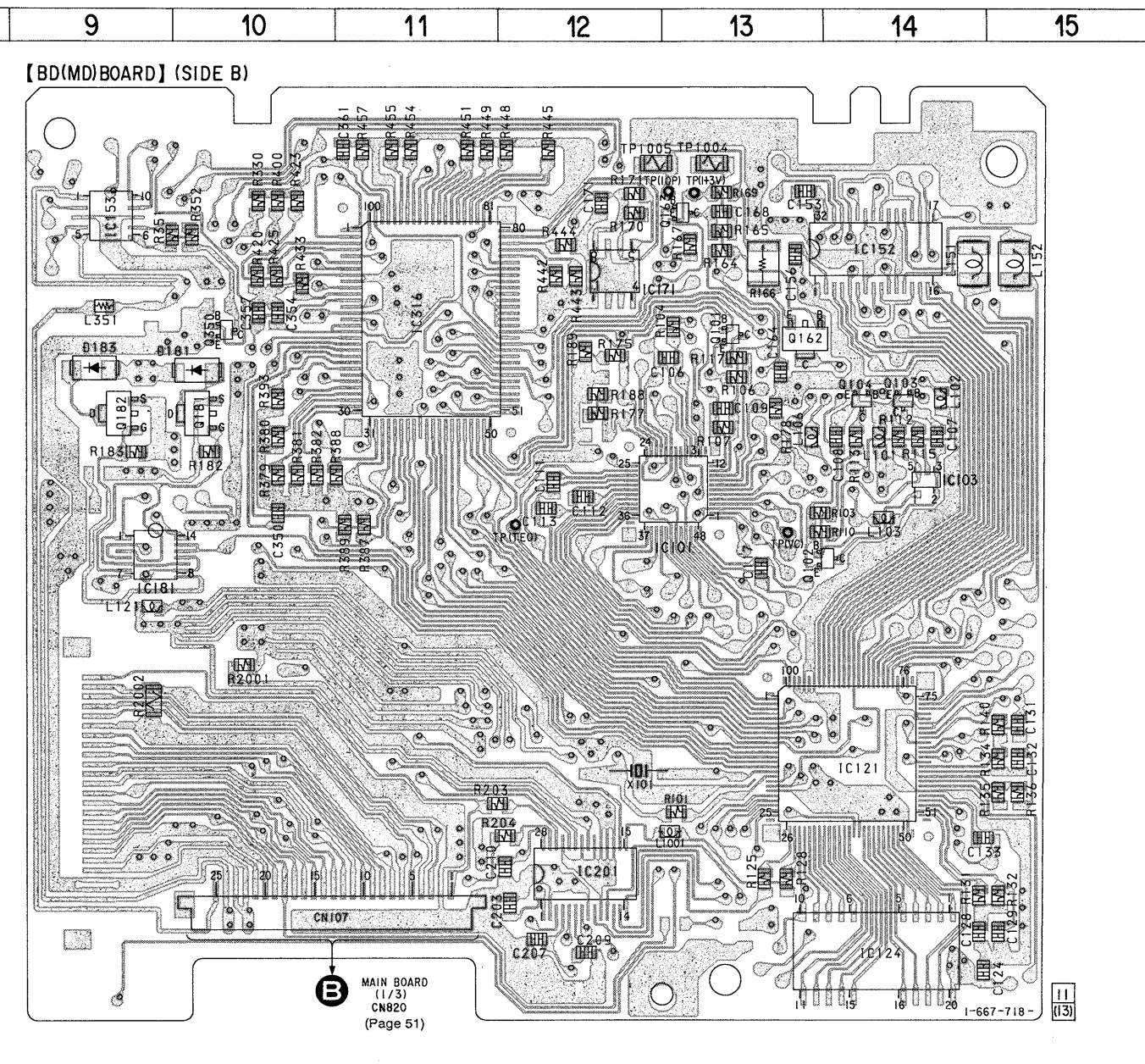
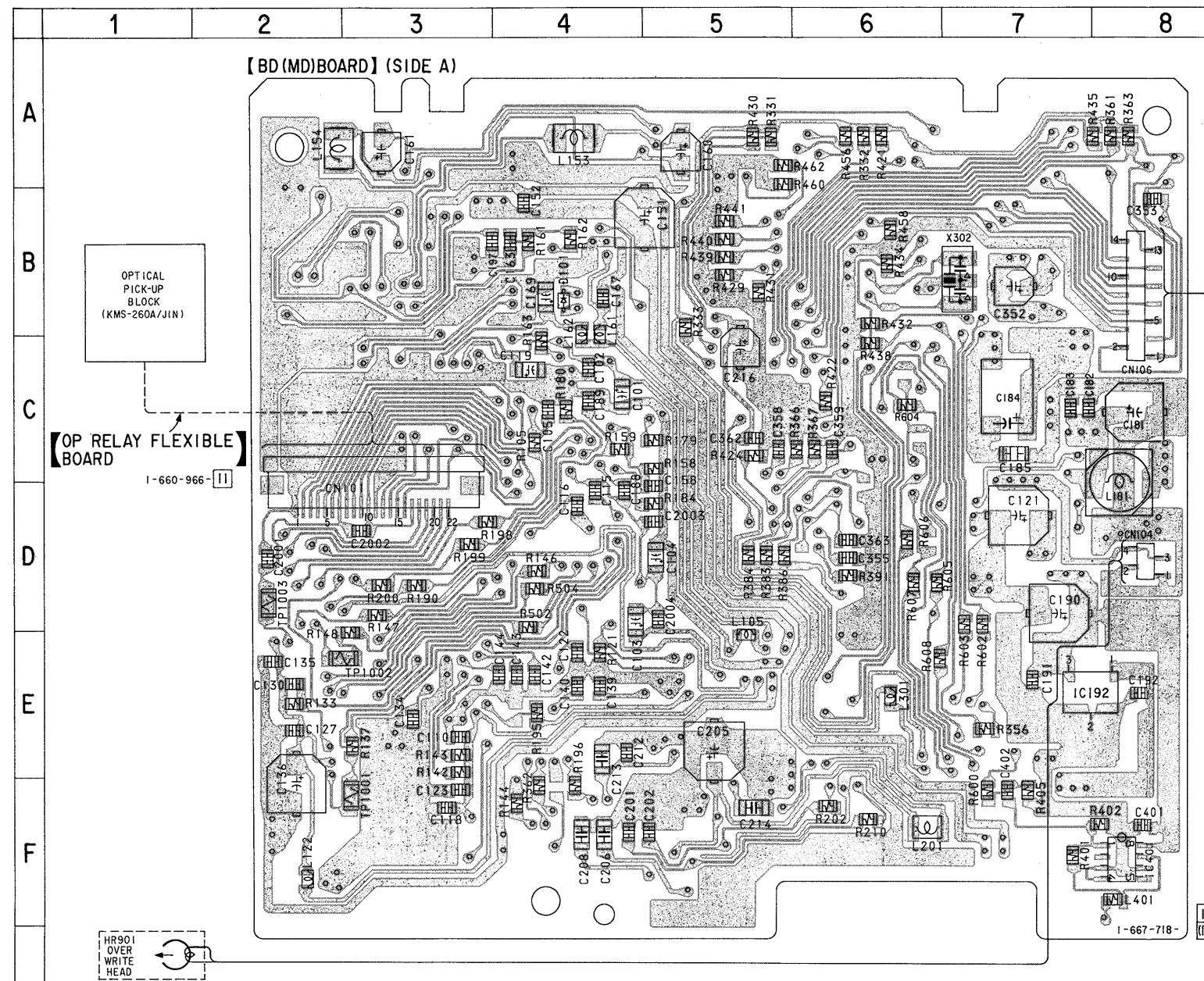

Note on Printed Wiring Board:

- : parts extracted from the component side.
- : parts extracted from the conductor side.
- △ : internal component.
- ▨ : Pattern from the side which enables seeing. (The other layers' patterns are not indicated.)

Caution:
 Pattern face side: Parts on the pattern face side seen from the pattern face are indicated.
 Parts face side: Parts on the parts face side seen from the parts face are indicated.

6-5. SCHEMATIC DIAGRAM - MD Section -

• See page 69 for IC Block Diagrams. • See page 65 for waveforms. • See page 75 to 79 for IC Pin Function Description.

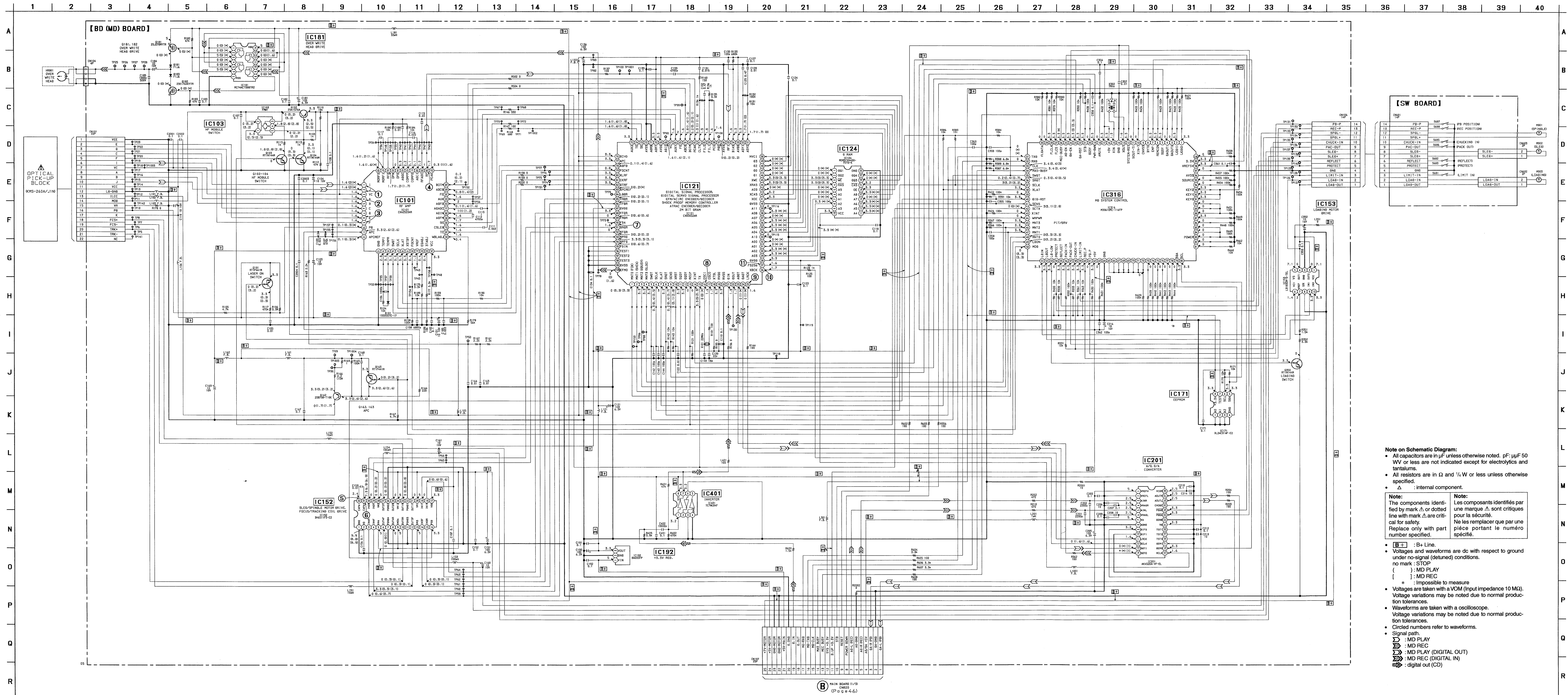

Note on Schematic Diagram:

- All capacitors are in μF unless otherwise noted. pF ; μF 50 WV or less are not indicated except for electrolytics and tantalums.
- All resistors are in Ω and $\frac{1}{4}$ W or less unless otherwise specified.
- Δ : internal component.

Note: The components identified by mark Δ are critical for safety. Replace only with part number specified.

Note: Les composants identifiés par une marque Δ sont critiques pour la sécurité. Ne les remplacer que par une pièce portant le numéro spécifié.

- \square : B+ Line.
- Voltages and waveforms are dc with respect to ground under no-signal (detuned) conditions.
- no mark: STOP
- (): MD PLAY
- []: MD REC
- *: impossible to measure
- Voltages are taken with a VOM (input impedance 10 M Ω). Voltage variations may be noted due to normal production tolerances.
- Waveforms are taken with an oscilloscope. Voltage variations may be noted due to normal production tolerances.
- Signal path.
- \rightarrow : MD PLAY
- \rightarrow : MD REC
- \rightarrow : MD PLAY (DIGITAL OUT)
- \rightarrow : MD REC (DIGITAL IN)
- \rightarrow : digital out (CD)

6-6. SCHEMATIC DIAGRAM -MAIN Section -
• See page 72 for IC Block Diagrams. • See page 66 for waveforms. • See page 80 and 81 for IC Pin Function Description.

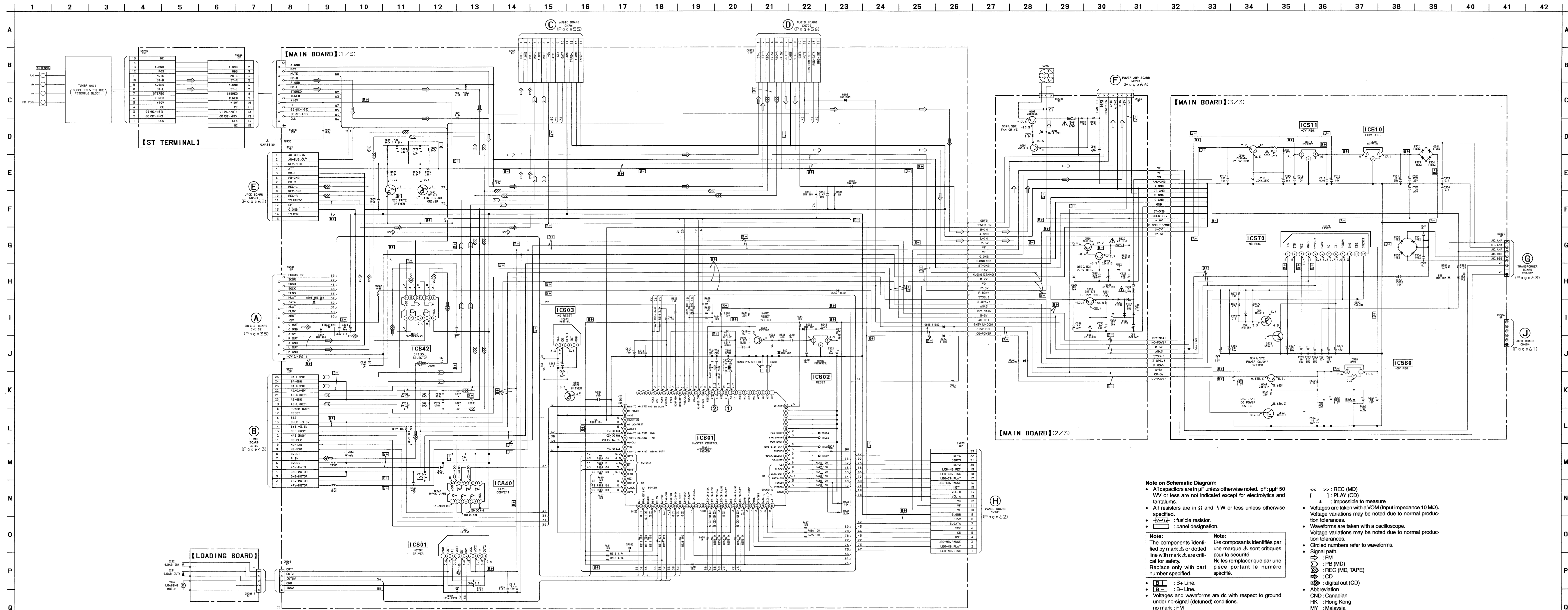

Note on Schematic Diagram:

- All capacitors are in μF unless otherwise noted. pF : $\mu\text{F}/50$ WV or less are not indicated except for electrolytics and tantalums.
- All resistors are in Ω and $\frac{1}{2}\text{W}$ or less unless otherwise specified.
- \square : fusible resistor.
- \square : panel designation.

Note:
The components identified by mark Δ or dotted line with mark Δ are critical for safety. Replace only with part number specified.

Note:
Les composants identifiés par une marque Δ sont critiques pour la sécurité. Ne les remplacer que par une pièce portant le numéro spécifié.

Note:
Voltages are taken with a VOM (input impedance 10 M Ω). Voltage variations may be noted due to normal production tolerances.

Note:
Waveforms are taken with an oscilloscope. Voltage variations may be noted due to normal production tolerances.

Note:
Circled numbers refer to waveforms.

Note:
Signal path:
 \rightarrow FM
 \rightarrow PB (MD)
 \rightarrow REC (MD, TAPE)
 \rightarrow CD
 • Abbreviation
 CND : Canadian
 HK : Hong Kong
 MY : Malaysia
 SP : Singapore

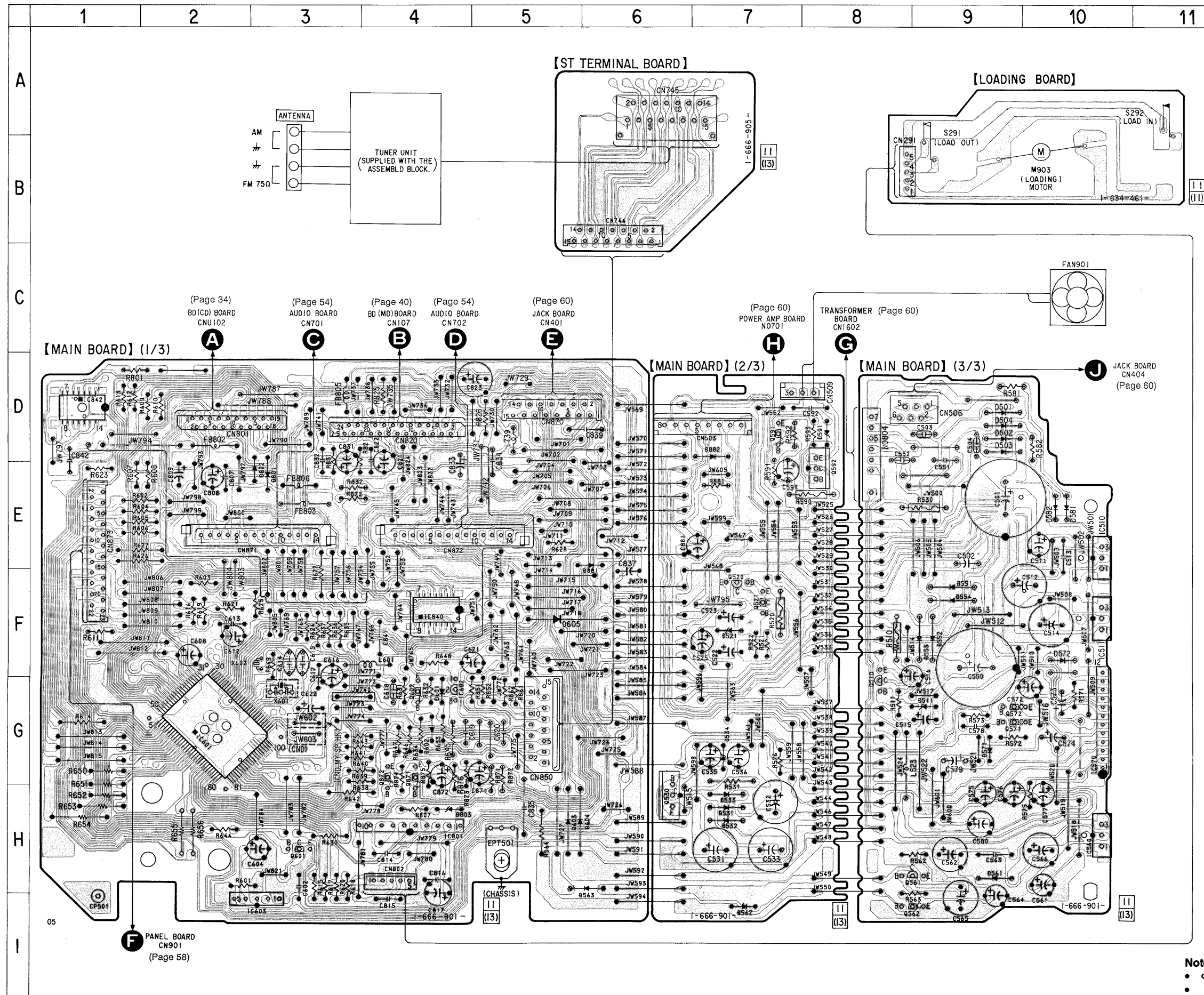

• Semiconductor Location

Ref. No.	Location	Ref. No.	Location
D501	D-9	D803	H-4
D502	D-9	D881	E-6
D503	D-9	D882	D-7
D504	D-9		
D511	G-9	IC510	E-10
D521	F-7	IC511	F-10
D531	H-7	IC560	H-10
D532	H-7	IC570	G-10
D533	H-7	IC601	G-2
D534	G-7	IC602	G-4
D551	F-9	IC603	I-3
D552	F-9	IC801	H-4
D553	F-9	IC840	F-4
D554	F-9	IC842	D-1
D561	H-9		
D562	I-7	Q510	G-8
D563	H-6	Q520	F-7
D571	G-9	Q521	F-7
D572	F-10	Q530	H-6
D581	E-10	Q561	H-8
D582	E-10	Q562	I-8
D591	D-8	Q571	G-9
D601	G-4	Q572	G-9
D602	G-4	Q591	D-7
D603	H-5	Q592	E-8
D604	H-5	Q601	H-3
D605	F-5	Q602	G-4
D801	E-3	Q871	G-4
D802	E-3	Q872	G-4

Note on Printed Wiring Board:

- : parts extracted from the component side.
- : parts mounted on the conductor side.
- △ : internal component.
- ▨ : Pattern from the side which enables seeing.
- Abbreviation
 CND : Canadian
 HK : Hong Kong
 MY : Malaysia
 SP : Singapore

6-8. PRINTED WIRING BOARD -AUDIO Section -
 • See page 26 for Circuit Boards Location.

• Semiconductor Location

Ref. No.	Location
D701	D-3
D1501	B-5
IC701	B-3
IC702	B-4
IC1500	B-5
IC1501	C-5
Q701	A-4
Q702	C-4
Q703	C-3
Q751	B-4
Q752	C-4

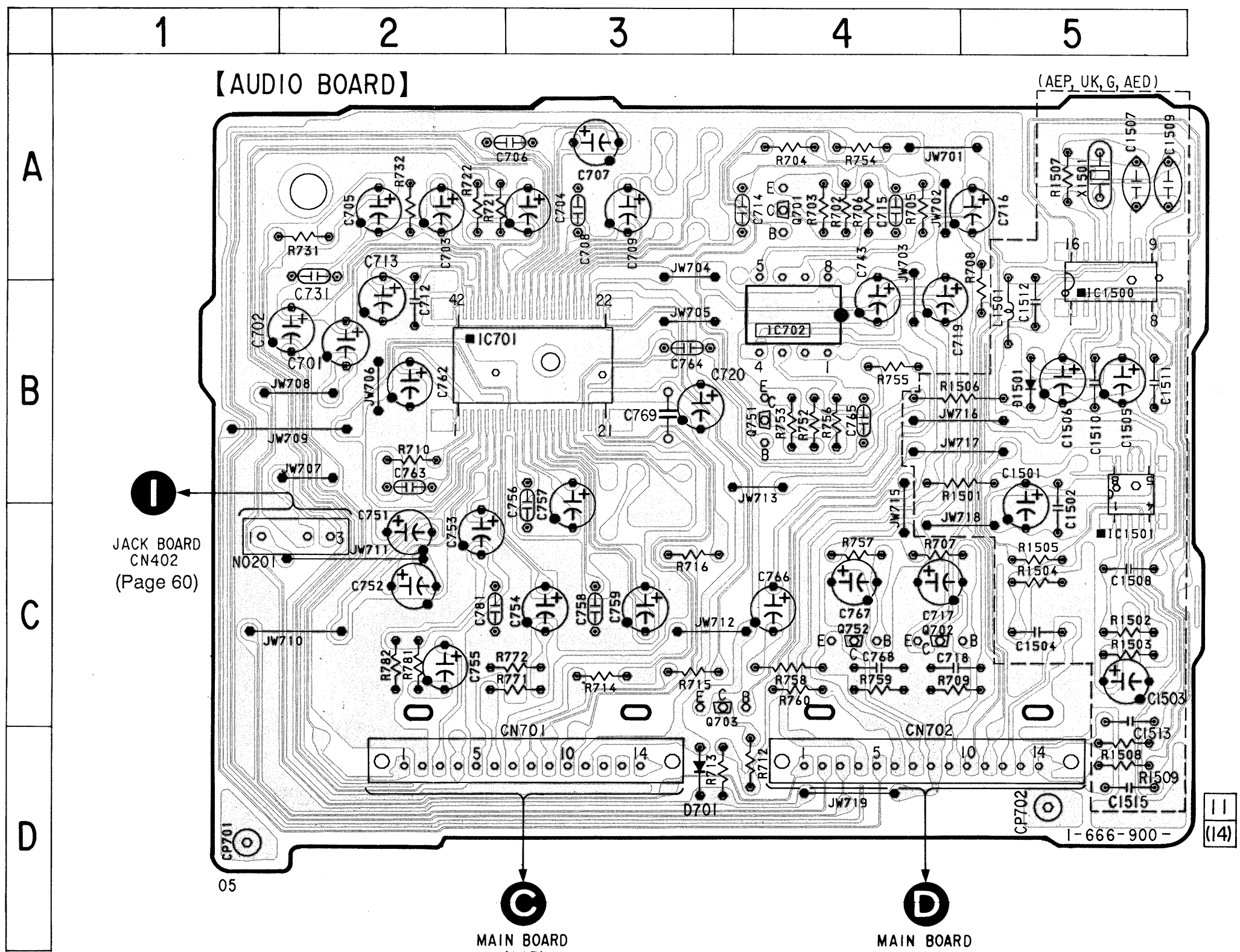

Note on Printed Wiring Board:

- : parts extracted from the component side.
- : parts mounted on the conductor side.
- ▨ : Pattern from the side which enables seeing.
- Abbreviation
 G : German
 AED : North European

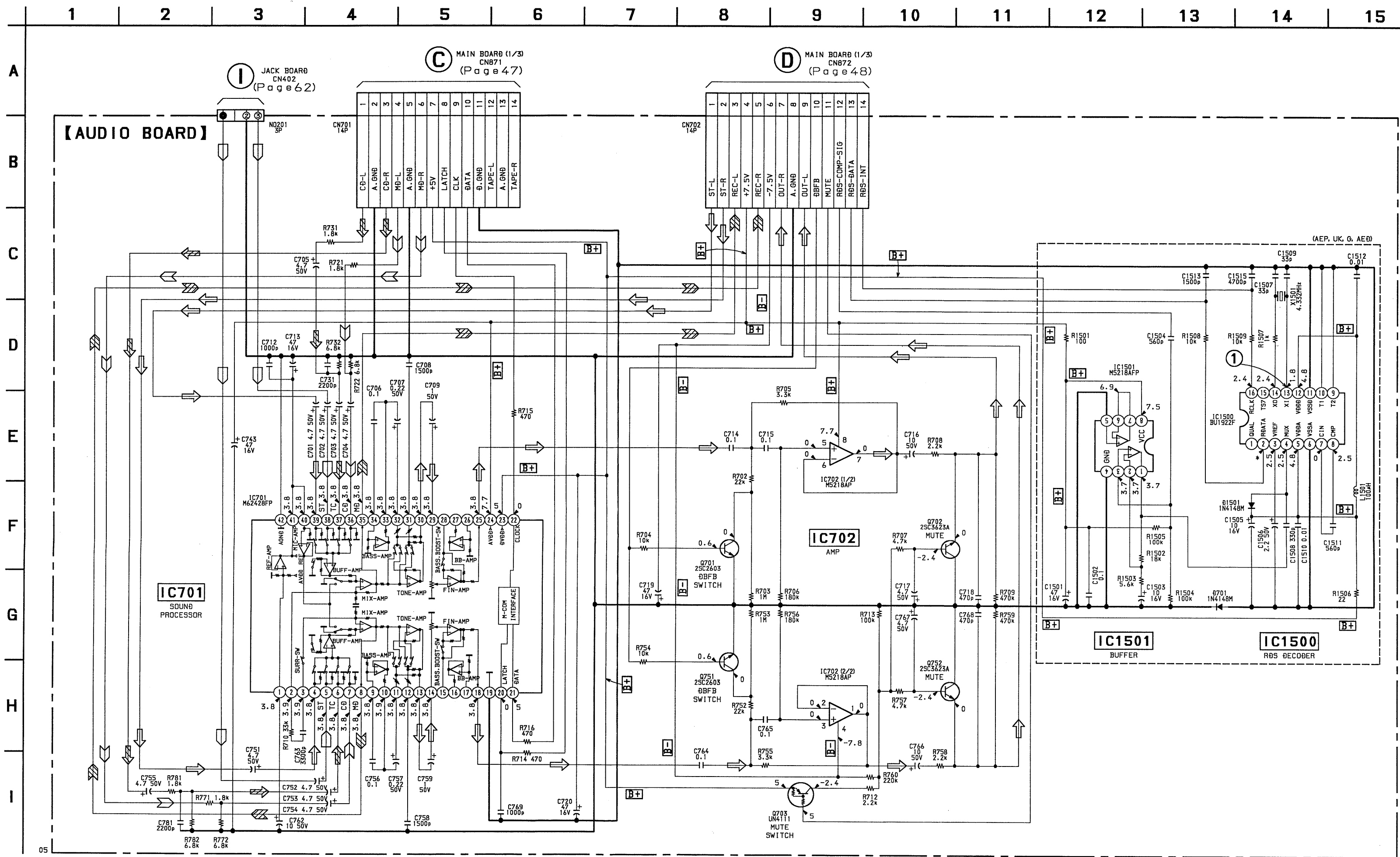

Note on Schematic Diagram:

- All capacitors are in μF unless otherwise noted. pF : μF 50 WV or less are not indicated except for electrolytics and tantalums.
- All resistors are in Ω and $1/4$ W or less unless otherwise specified.
- B+ : B+ Line.
- B- : B- Line.
- Voltagess and waveforms are dc with respect to ground under no-signal (detuned) conditions.
- no mark : FM
- * : Impossible to measure
- Voltagess are taken with a VOM (Input impedance 10 $\text{M}\Omega$). Voltage variations may be noted due to normal production tolerances.
- Waveforms are taken with an oscilloscope. Voltage variations may be noted due to normal production tolerances.
- Circled numbers refer to waveforms.
- Signal path.
- FM : FM
- PB (MD) : PB (MD)
- REC (MD, TAPE) : REC (MD, TAPE)
- PB (TAPE) : PB (TAPE)
- CD : CD
- Abbreviation
- G : German
- AED : North European

• See page 26 for Circuit Boards Location.

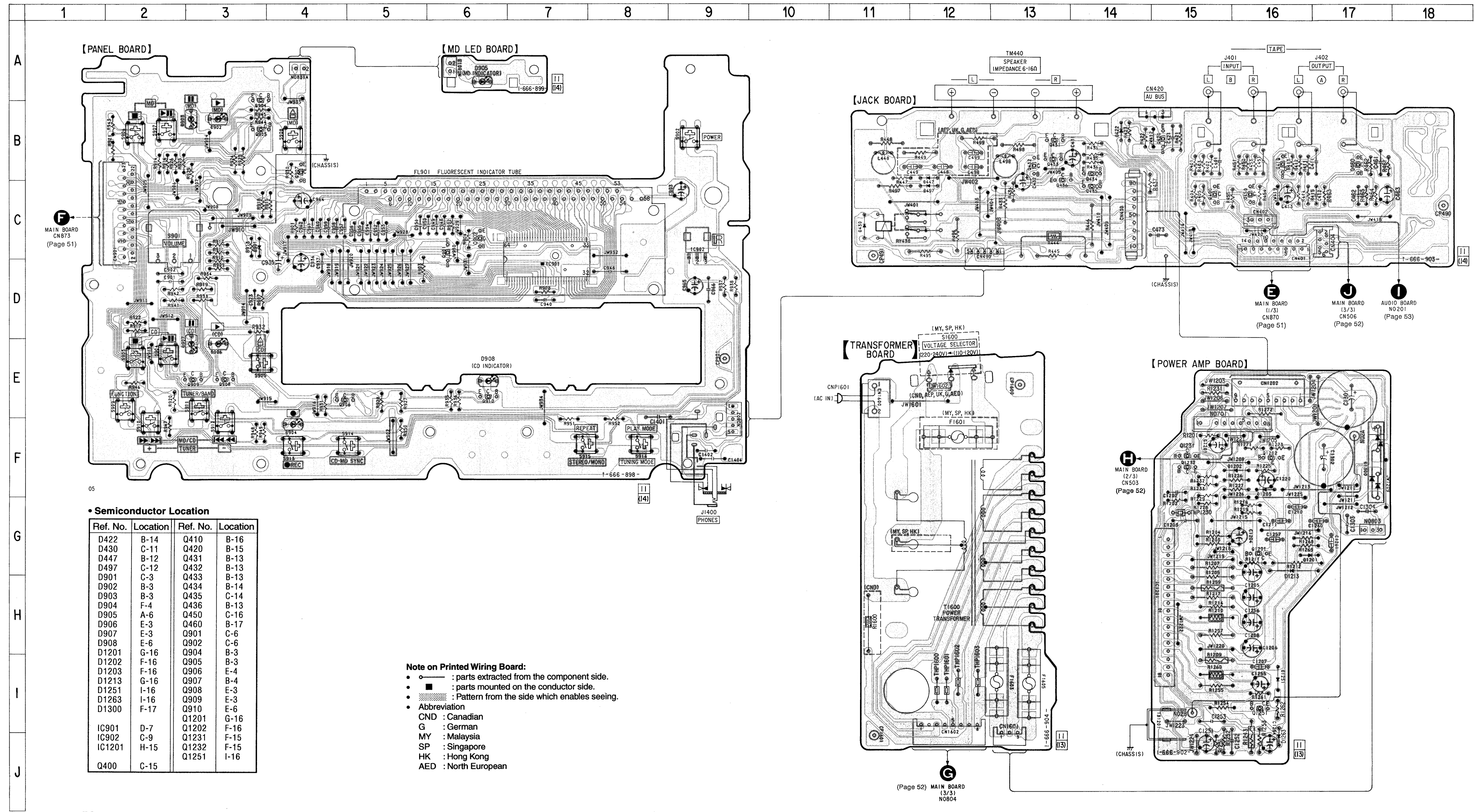

• Semiconductor Location

Ref. No.	Location	Ref. No.	Location
D422	B-14	Q410	B-16
D430	C-11	Q420	B-15
D447	B-12	Q431	B-13
D497	C-12	Q432	B-13
D901	C-3	Q433	B-13
D902	B-3	Q434	B-14
D903	B-3	Q435	C-14
D904	F-4	Q436	B-13
D905	A-6	Q450	C-16
D906	E-3	Q460	B-17
D907	E-3	Q901	C-6
D908	E-6	Q902	C-6
D1201	G-16	Q904	B-3
D1202	F-16	Q905	B-3
D1203	F-16	Q906	E-4
D1213	G-16	Q907	B-4
D1251	I-16	Q908	E-3
D1263	I-16	Q909	E-3
D1300	F-17	Q910	E-6
		Q1201	G-16
IC901	D-7	Q1202	F-16
IC902	C-9	Q1231	F-15
IC1201	H-15	Q1232	F-15
		Q1251	I-16
Q400	C-15		

Note on Printed Wiring Board:

- : parts extracted from the component side.
- : parts mounted on the conductor side.
- : Pattern from the side which enables seeing.
- Abbreviation
 - CND : Canadian
 - G : German
 - MY : Malaysia
 - SP : Singapore
 - HK : Hong Kong
 - AED : North European

6-11. SCHEMATIC DIAGRAM -PANEL/POWER Section-

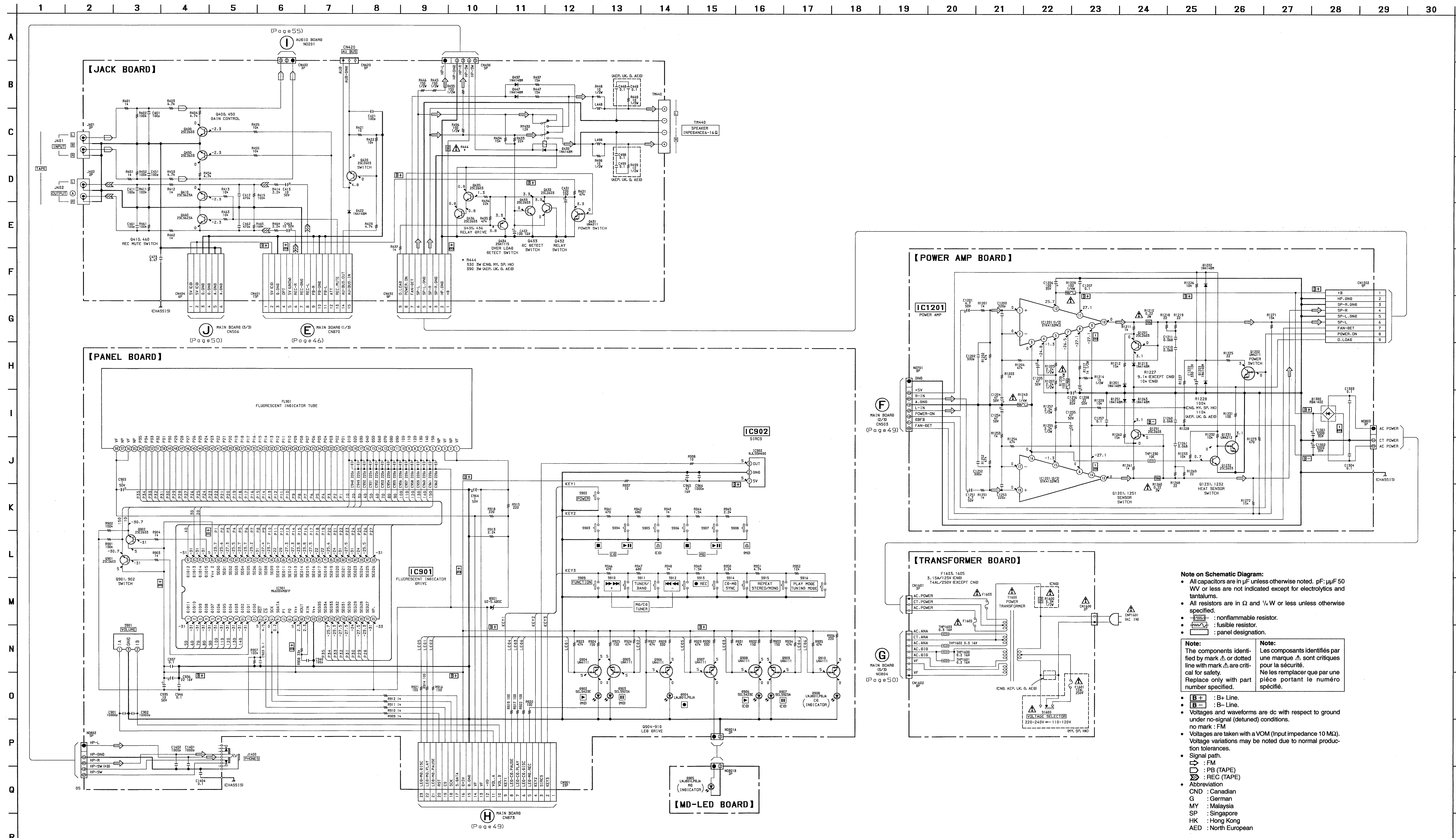

Note on Schematic Diagram:

- All capacitors are in μF unless otherwise noted. pF: μF 50 WV or less are not indicated except for electrolytics and tantalums.
- All resistors are in Ω and $\frac{1}{4}\text{W}$ or less unless otherwise specified.
- \square : nonflammable resistor.
- \square : fusible resistor.
- \square : panel designation.

Note:
The components identified by mark Δ or dotted line with mark Δ are critical for safety. Replace only with part number specified.

Note:
Les composants identifiés par une marque Δ sont critiques pour la sécurité. Ne les remplacer que par une pièce portant le numéro spécifié.

- \square : B+ Line.
- \square : B- Line.
- Voltagages and waveforms are dc with respect to ground under no-signal (detuned) conditions.
- no mark : FM
- Voltagages are taken with a VOM (input impedance 10 M Ω). Voltage variations may be noted due to normal production tolerances.
- Signal path.
- \square : FM
- \square : PB (TAPE)
- \square : REC (TAPE)
- Abbreviation
- CND : Canadian
- G : German
- MY : Malaysia
- SP : Singapore
- HK : Hong Kong
- AED : North European

• Waveforms

– CD Section –

① IC101 ⑳ (RFO) (PLAY Mode)
500 mV/DIV, 500 ns/DIV

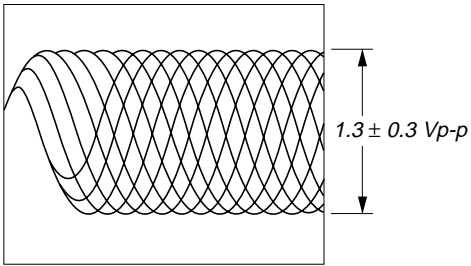

② IC101 ㉔ (TEI) (PLAY Mode)
50 mV/DIV, 1 μs/DIV

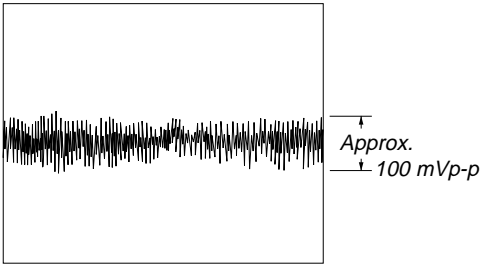

③ IC101 ② (FEI) (PLAY Mode)
50 mV/DIV, 1 μs/DIV

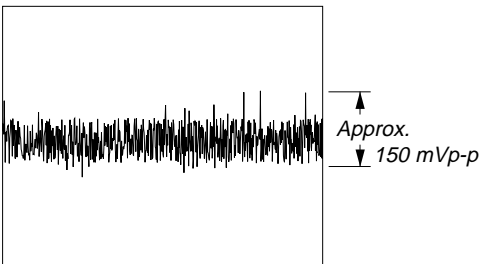

④ IC103 ③ (MDP) (PLAY Mode)

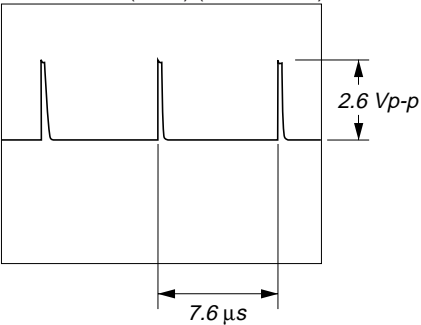

⑤ IC103 ㉔ (RFCK)

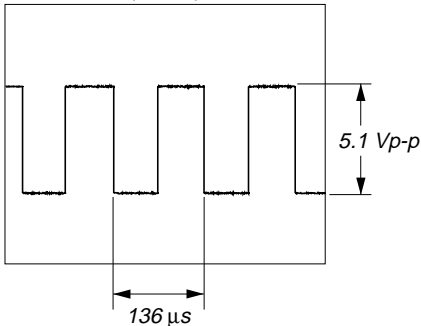

⑥ IC103 ㉔ (XPCK)

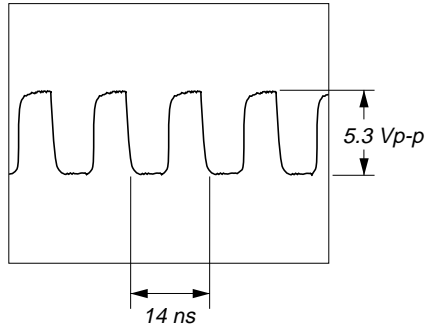

⑦ IC103 ㉔ (BCLK)

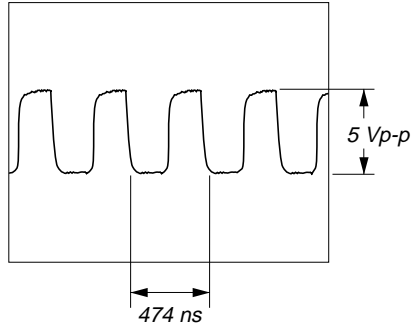

⑧ IC103 ㉔ (LRCK)

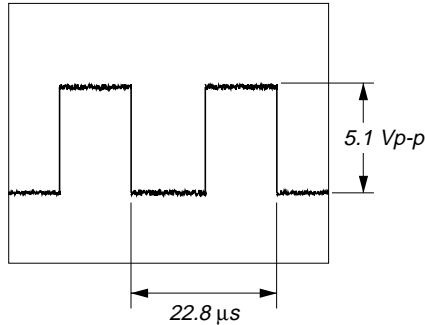

⑨ IC104 ⑥ (XTO)

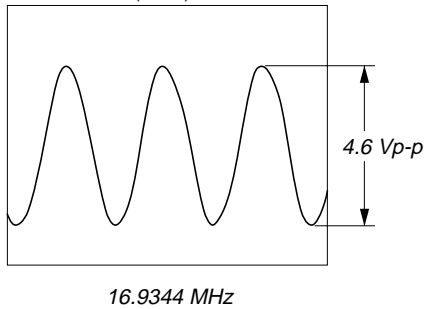

– MD Section –

① IC101 ①, ② (I, J) (PLAY Mode)

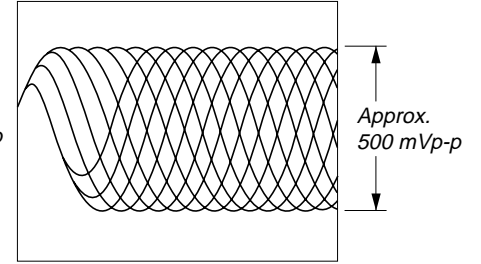

② IC101 ④ (A) (PLAY Mode)

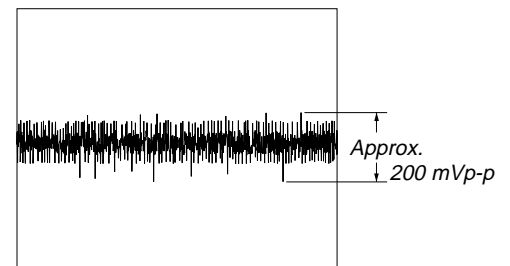

③ IC101 ⑧, ⑨ (E, F) (PLAY Mode)

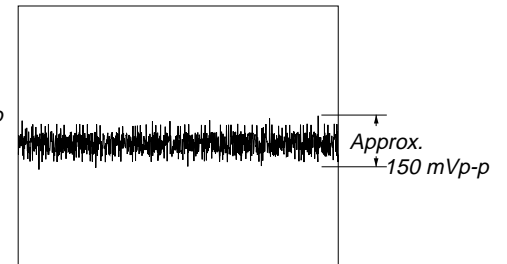

④ IC101 ㉔ (RF) (PLAY Mode)

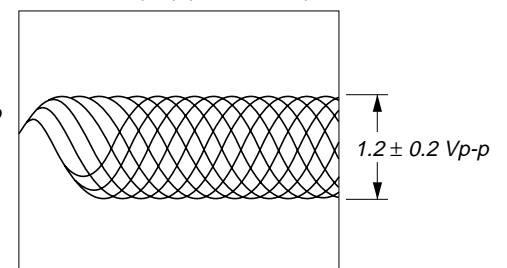

⑤ IC152 ㉔ (CAPA-) (PLAY Mode)

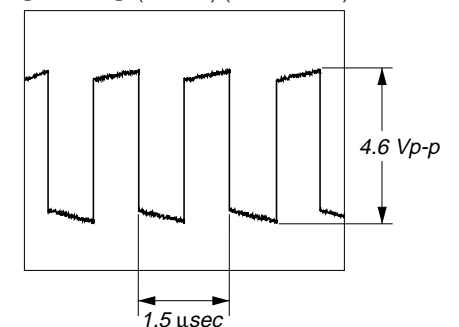

6 IC152 31 (CAPA+) (Play Mode)

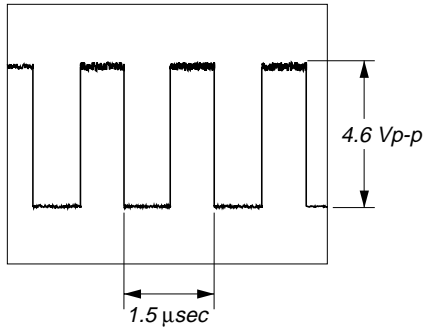

11 IC121 27 (FS256)

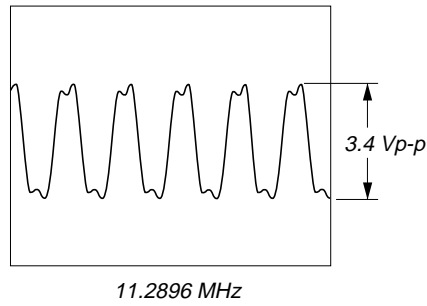

7 IC121 30 (FS4)

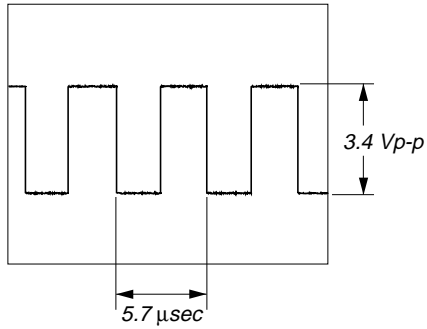

– MAIN Section –

1 IC601 11 (XI)

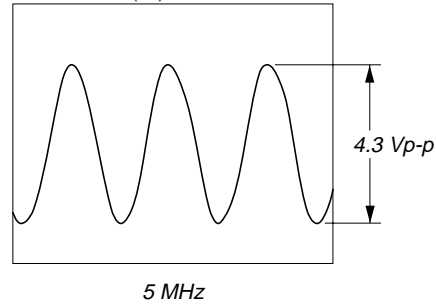

8 IC121 16 (OSCI)

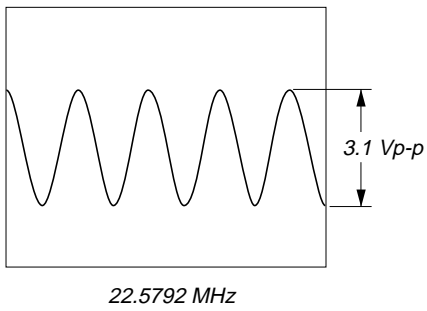

1 IC601 14 (XTI)

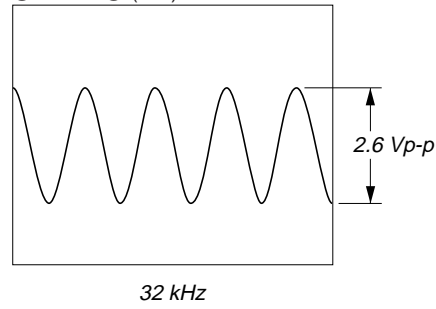

9 IC121 25 (LRCK)

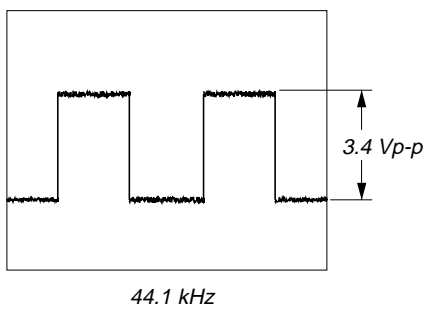

– AUDIO Section –

1 IC1500 13 (XI)

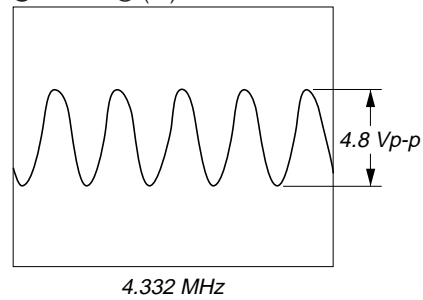

10 IC121 26 (XBCK)

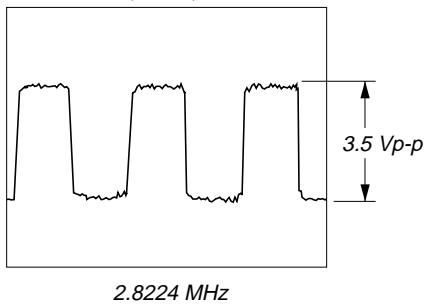

• IC Block Diagrams
 – CD Section –
 IC101 CXA1782BQ

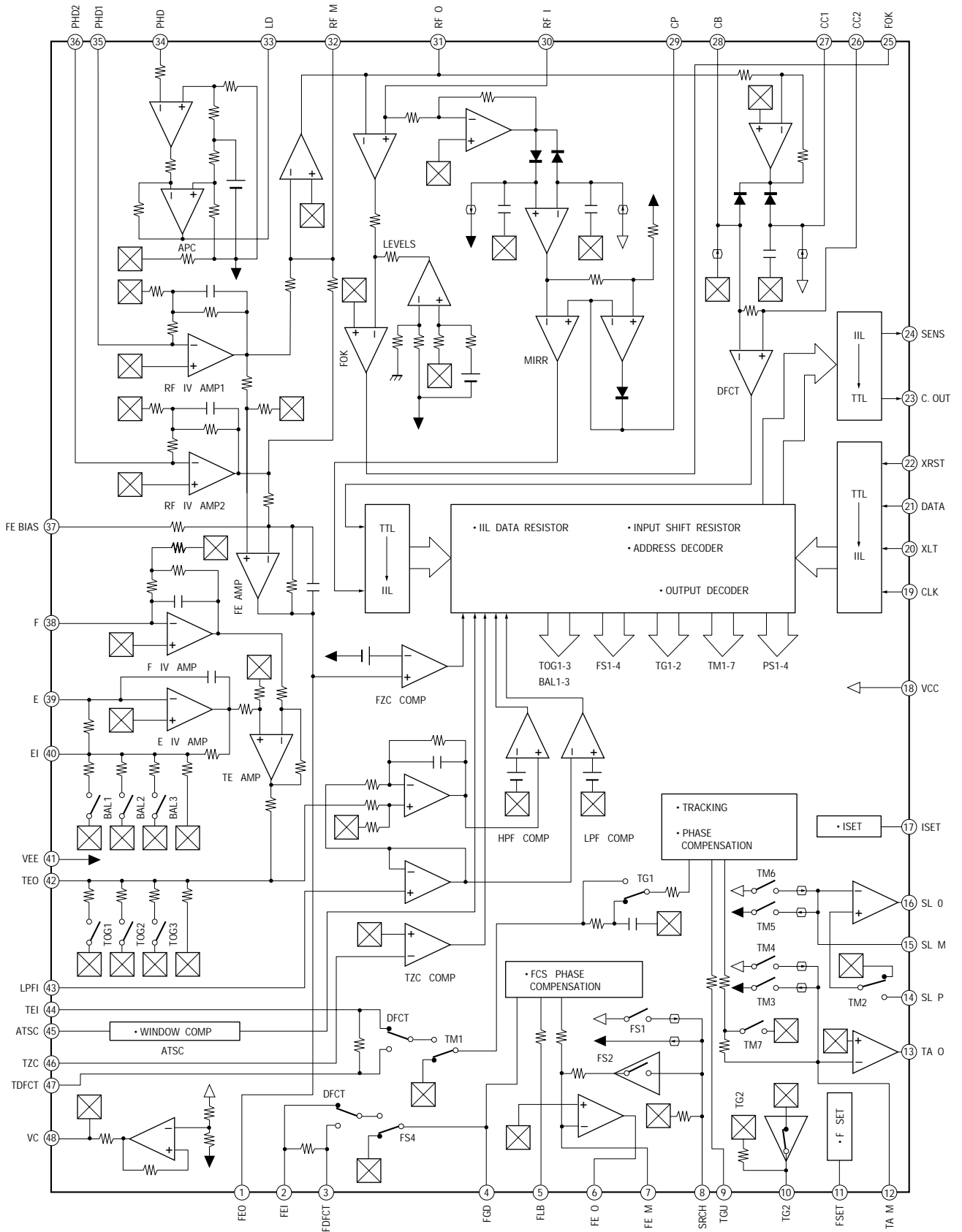

IC102 BA6397FP

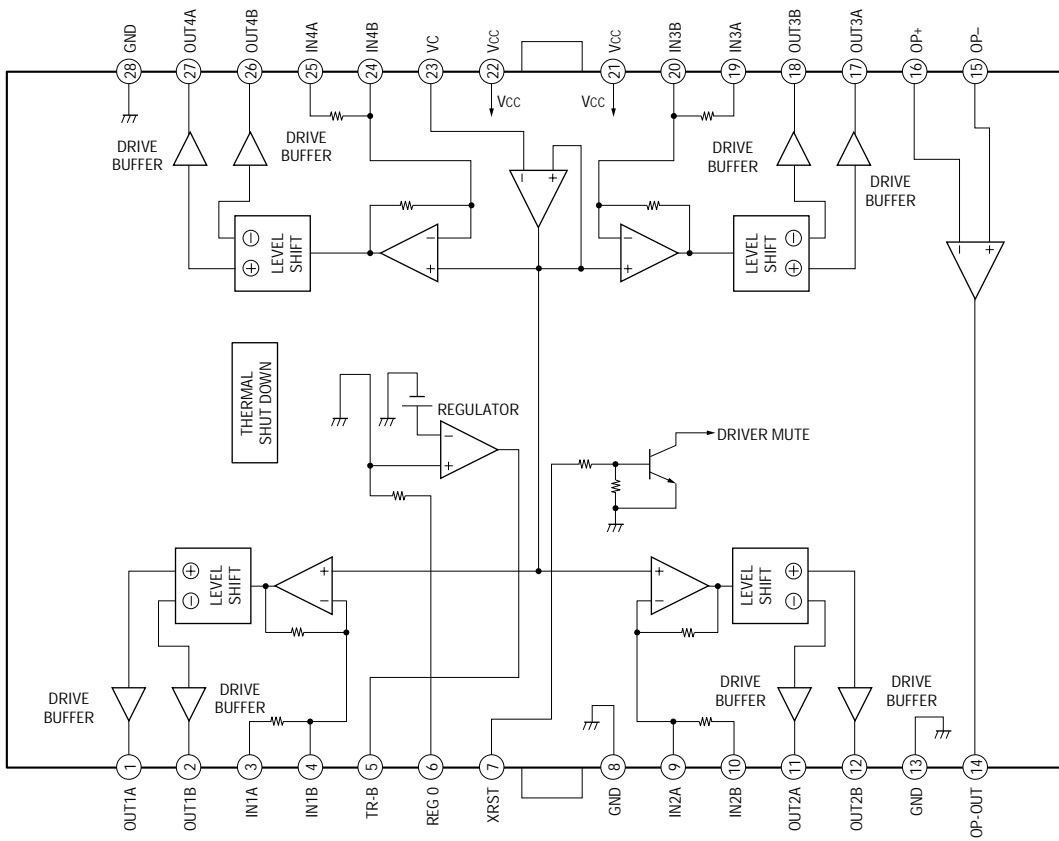

IC103 CXD2507AQ

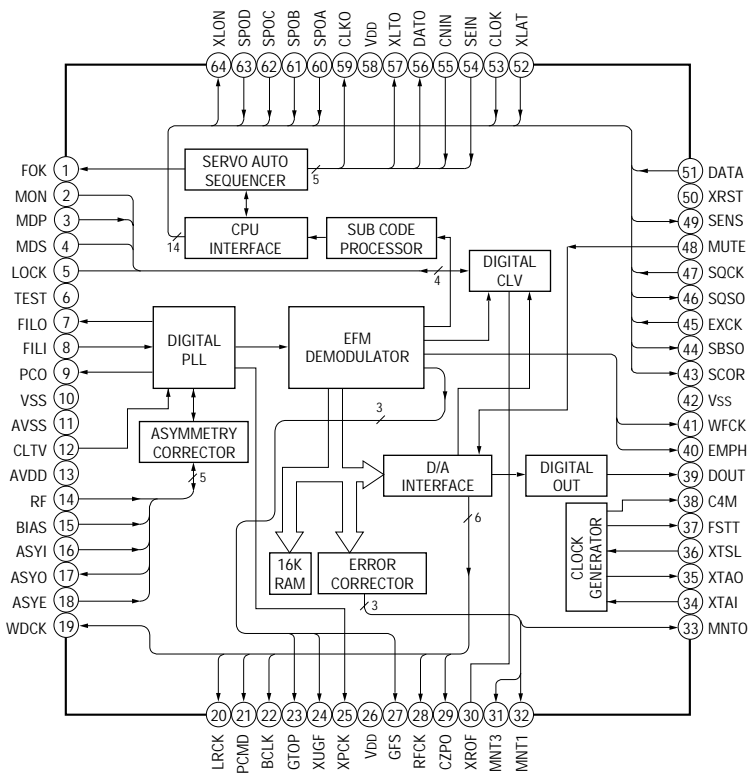

IC104 PCM1710U-B

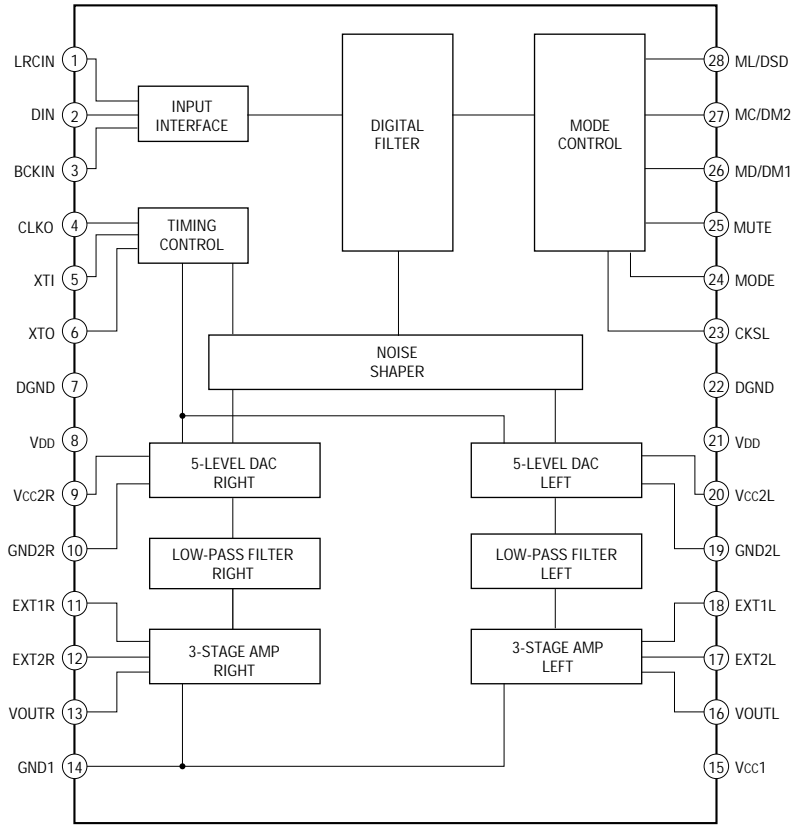

– MD Section –

IC153 LB1830-S-TE-L

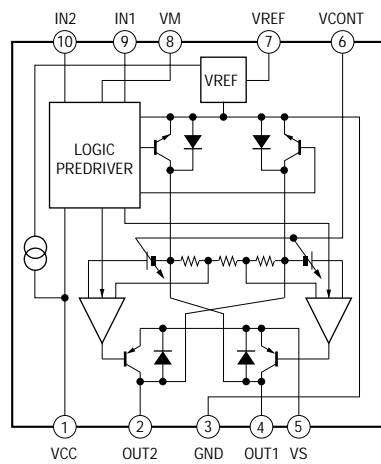

IC201 AK4520A-VF-E2

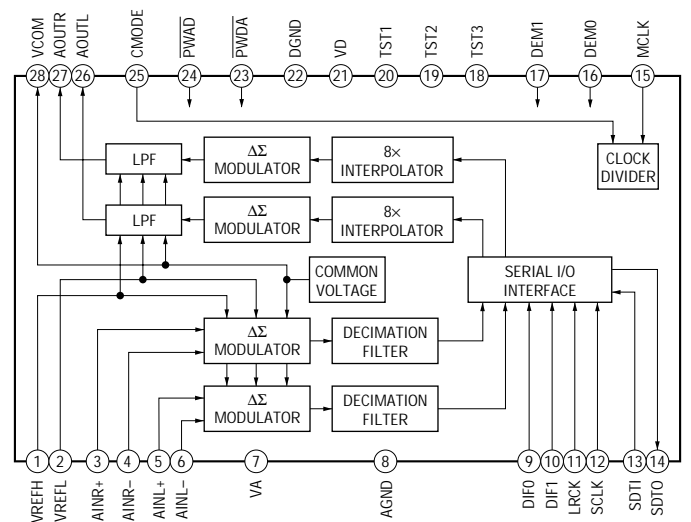

IC101 CXA2523AR

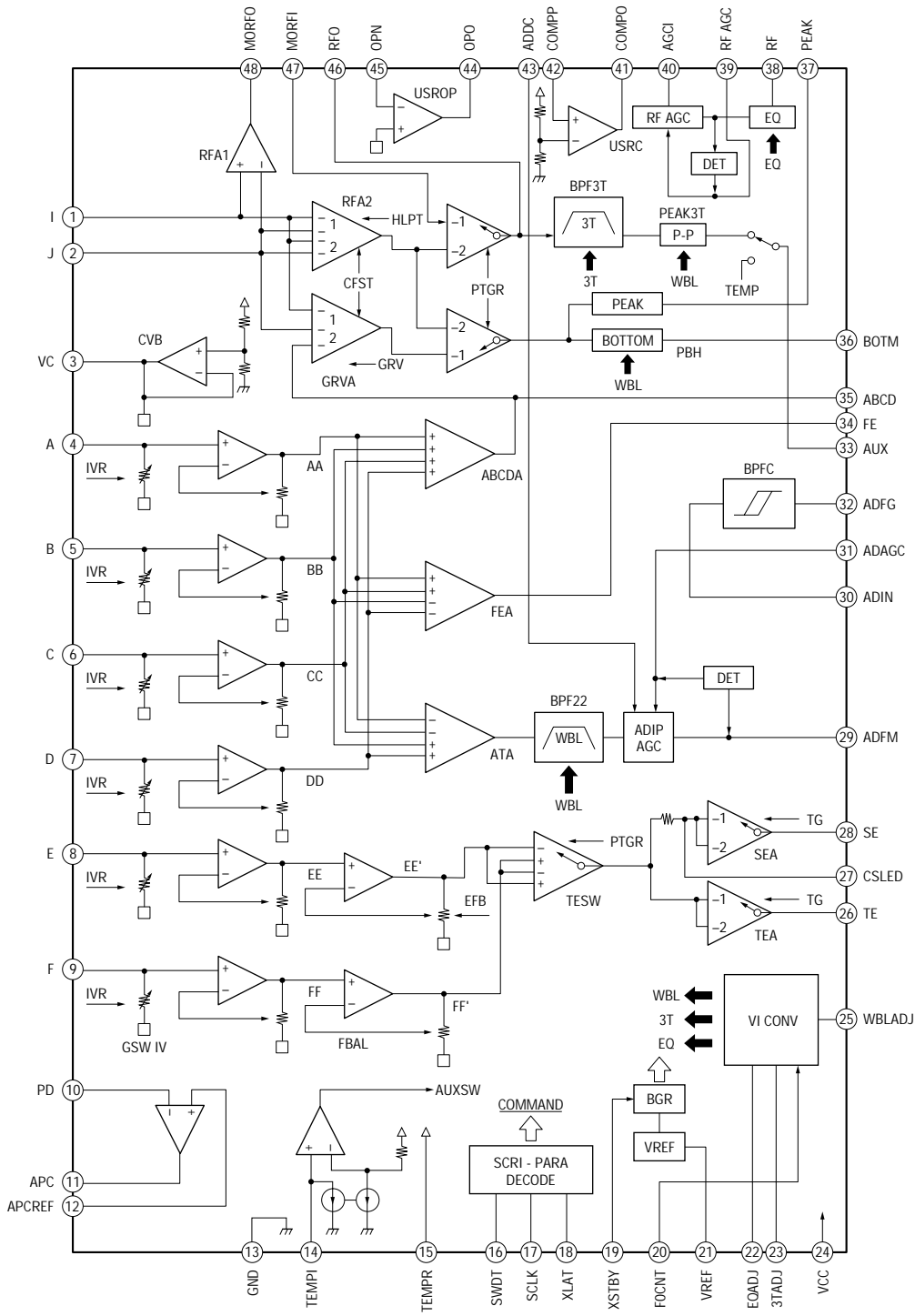

IC121 CXD2652AR

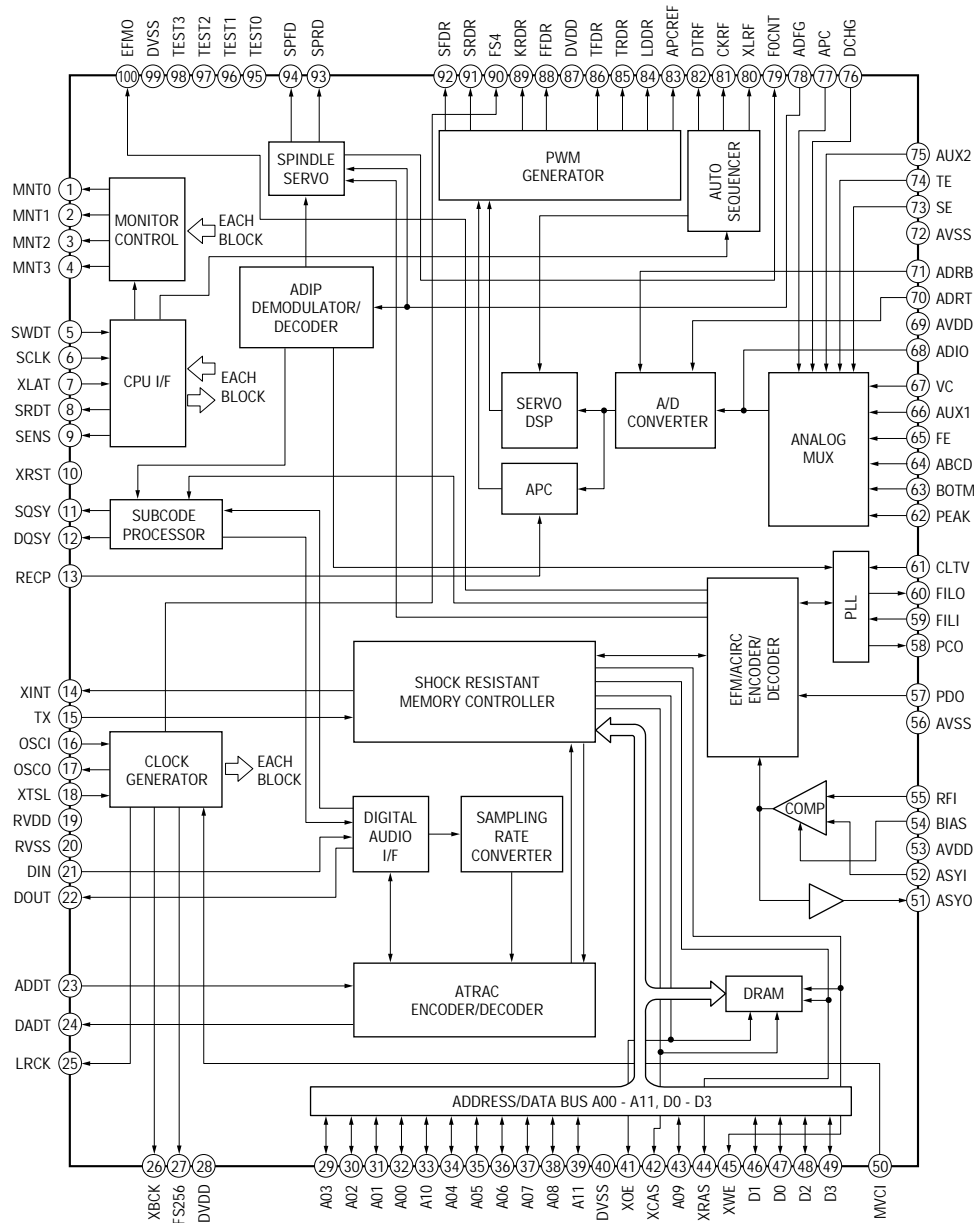

IC152 BH6511FS-E2

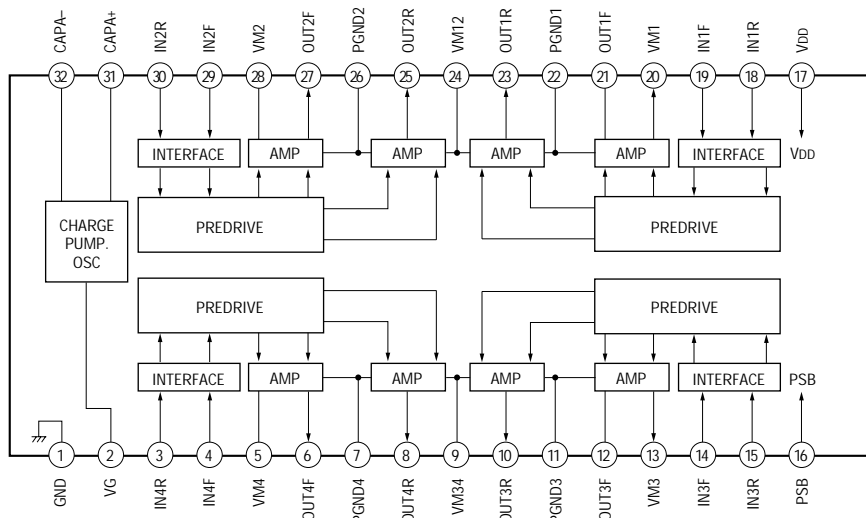

– MAIN Section –
IC570 LA5620

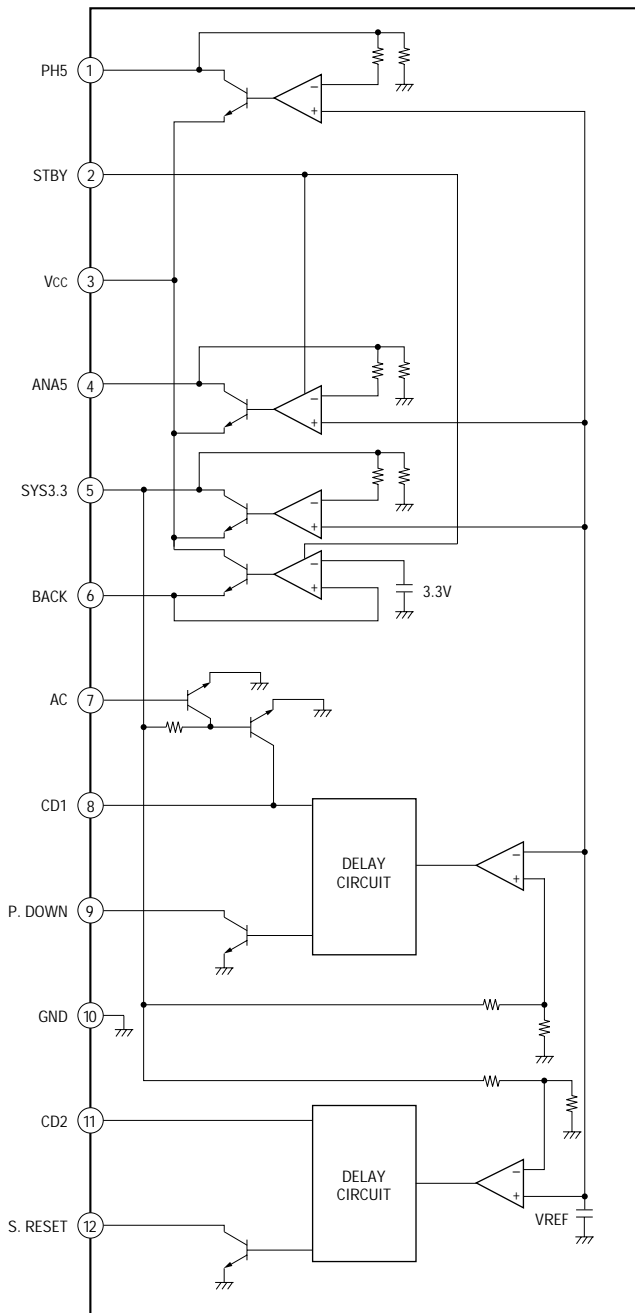

IC603 M62016L

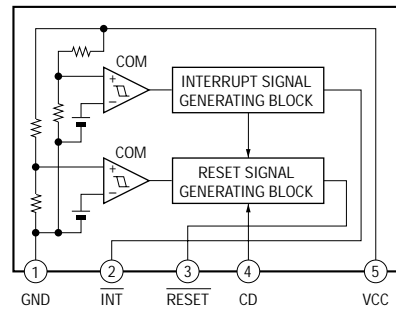

IC801 LB1641

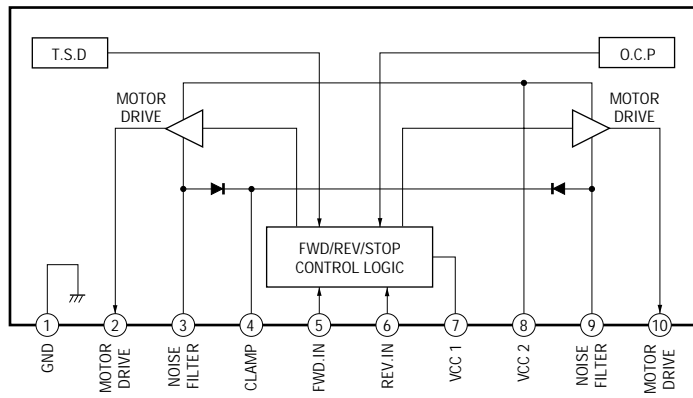

**– AUDIO Section –
IC1500 BU1922F**

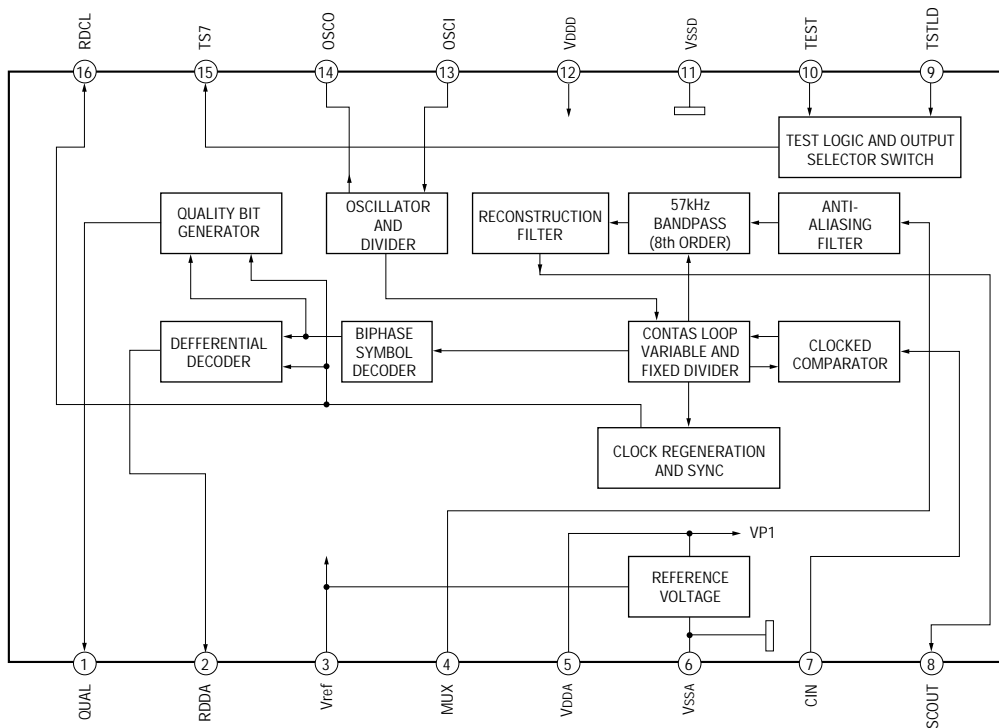

6-12. IC PIN FUNCTION DESCRIPTION

• BD (MD) BOARD IC101 CXA2523AR (RF AMPLIFIER)

Pin No.	Pin Name	I/O	Function
1	I	I	I-V converted RF signal I input from the optical pick-up block detector
2	J	I	I-V converted RF signal J input from the optical pick-up block detector
3	VC	O	Middle point voltage (+1.65V) generation output terminal
4 to 9	A to F	I	Signal input from the optical pick-up detector
10	PD	I	Light amount monitor input terminal
11	APC	O	Laser amplifier output terminal to the automatic power control circuit
12	APCREF	I	Reference voltage input terminal for setting laser power
13	GND	—	Ground terminal
14	TEMPI	I	Connected to the temperature sensor
15	TEMPR	O	Output terminal for a temperature sensor reference voltage
16	SWDT	I	Writing serial data input from the CXD2652AR (IC121)
17	SCLK	I	Serial clock signal input from the CXD2652AR (IC121)
18	XLAT	I	Serial latch signal input from the CXD2652AR (IC121)
19	XSTBY	I	Standby signal input terminal “L”: standby (fixed at “H” in this set)
20	F0CNT	I	Center frequency control voltage input terminal of internal circuit (BPF22, BPF3T, EQ) input from the CXD2652AR (IC121)
21	VREF	O	Reference voltage output terminal Not used (open)
22	EQADJ	I	Center frequency setting terminal for the internal circuit (EQ)
23	3TADJ	I	Center frequency setting terminal for the internal circuit (BPF3T)
24	VCC	—	Power supply terminal (+3.3V)
25	WBLADJ	I	Center frequency setting terminal for the internal circuit (BPF22)
26	TE	O	Tracking error signal output to the CXD2652AR (IC121)
27	CSLED	I	Connected to the external capacitor for low-pass filter of the sled error signal
28	SE	O	Sled error signal output to the CXD2652AR (IC121)
29	ADFM	O	FM signal output of the ADIP
30	ADIN	I	Receives a ADIP FM signal in AC coupling
31	ADAGC	I	Connected to the external capacitor for ADIP AGC
32	ADFG	O	ADIP duplex signal (22.05 kHz \pm 1 kHz) output to the CXD2652AR (IC121)
33	AUX	O	Auxiliary signal (I3 signal/temperature signal) output to the CXD2652AR (IC121)
34	FE	O	Focus error signal output to the CXD2652AR (IC121)
35	ABCD	O	Light amount signal (ABCD) output to the CXD2652AR (IC121)
36	BOTM	O	Light amount signal (RF/ABCD) bottom hold output to the CXD2652AR (IC121)
37	PEAK	O	Light amount signal (RF/ABCD) peak hold output to the CXD2652AR (IC121)
38	RF	O	Playback EFM RF signal output to the CXD2652AR (IC121)
39	RFAGC	I	Connected to the external capacitor for RF auto gain control circuit
40	AGCI	I	Receives a RF signal in AC coupling
41	COMPO	O	User comparator output terminal Not used (open)
42	COMPP	I	User comparator input terminal Not used (fixed at “L”)
43	ADDC	I	Connected to the external capacitor for cutting the low band of the ADIP amplifier
44	OPO	O	User operational amplifier output terminal Not used (open)
45	OPN	I	User operational amplifier inversion input terminal Not used (fixed at “L”)
46	RFO	O	RF signal output terminal
47	MORFI	I	Receives a MO RF signal in AC coupling
48	MORFO	O	MO RF signal output terminal

• **BD (MD) BOARD IC121 CXD2652AR**

(DIGITAL SIGNAL PROCESSOR, DIGITAL SERVO PROCESSOR, EFM/ACIRC ENCODER/DECODER, SHOCK PROOF MEMORY CONTROLLER, ATRAC ENCODER/DECODER, 2M BIT D-RAM)

Pin No.	Pin Name	I/O	Function
1	MNT0 (FOK)	O	Focus OK signal output to the MD system controller (IC316) "H" is output when focus is on
2	MNT1 (SHCK)	O	Track jump detection signal output to the MD system controller (IC316)
3	MNT2 (XBUSY)	O	Monitor 2 signal output to the MD system controller (IC316)
4	MNT3 (SLOC)	O	Monitor 3 signal output to the MD system controller (IC316)
5	SWDT	I	Writing data signal input from the MD system controller (IC316)
6	SCLK	I	Serial clock signal input from the MD system controller (IC316)
7	XLAT	I	Serial latch signal input from the MD system controller (IC316)
8	SRDT	O (3)	Reading data signal output to the MD system controller (IC316)
9	SENS	O (3)	Internal status (SENSE) output to the MD system controller (IC316)
10	$\overline{\text{XRST}}$	I	Reset signal input from the MD system controller (IC316) "L": reset
11	SQSY	O	Subcode Q sync (SCOR) output to the MD system controller (IC316) "L" is output every 13.3 msec Almost all, "H" is output
12	DQSY	O	Digital In U-bit CD format subcode Q sync (SCOR) output to the MD system controller (IC316) "L" is output every 13.3 msec Almost all, "H" is output
13	RECP	I	Laser power selection signal input from the MD system controller (IC316) "H": recording mode, "L": playback mode
14	XINT	O	Interrupt status output to the MD system controller (IC316)
15	TX	I	Recording data output enable signal input from the MD system controller (IC316) Writing data transmission timing input (Also serves as the magnetic head on/off output)
16	OSCI	I	System clock signal (512Fs=22.5792 MHz) input terminal
17	OSCO	O	System clock signal (512Fs=22.5792 MHz) output terminal
18	XTSL	I	Input terminal for the system clock frequency setting "L": 45.1584 MHz, "H": 22.5792 MHz (fixed at "H" in this set)
19	RVDD	—	Power supply terminal (+3.3V) (digital system)
20	RVSS	—	Ground terminal (digital system)
21	DIN	I	Digital audio signal input terminal when recording mode (for optical in)
22	DOUT	O	Digital audio signal output terminal when playback mode (for optical out) Not used
23	ADDT	I	Recording data input from the A/D, D/A converter (IC201)
24	DADT	O	Playback data output to the A/D, D/A converter (IC201)
25	LRCK	O	L/R sampling clock signal (44.1 kHz) output to the A/D, D/A converter (IC201)
26	XBCK	O	Bit clock signal (2.8224 MHz) output to the A/D, D/A converter (IC201)
27	FS256	O	Clock signal (11.2896 MHz) output to the A/D, D/A converter (IC201)
28	DVDD	—	Power supply terminal (+3.3V) (digital system)
29	A03	O	Address signal output to the external D-RAM (IC124)
30	A02	O	
31	A01	O	
32	A00	O	
33	A10	O	
34	A04	O	
35	A05	O	
36	A06	O	
37	A07	O	
38	A08	O	
39	A11	O	

* I (A) for analog input, O (3) for 3-state output, and O (A) for analog output in the column I/O.

Pin No.	Pin Name	I/O	Function
40	DVSS	—	Ground terminal (digital system)
41	XOE	O	Output enable signal output to the external D-RAM (IC124)
42	XCAS	O	Column address strobe signal output to the external D-RAM (IC124)
43	A09	O	Address signal output to the external D-RAM (IC124)
44	XRAS	O	Row address strobe signal output to the external D-RAM (IC124)
45	XWE	O	Write enable signal output to the external D-RAM (IC124)
46	D1	I/O	Two-way data bus for the external D-RAM (IC124)
47	D0	I/O	
48	D2	I/O	
49	D3	I/O	
50	MVCI	I	Digital in PLL oscillation input from the external VCO Not used (fixed at “L”)
51	ASYO	O	Playback EFM full-swing output
52	ASYI	I (A)	Playback EFM asymmetry comparator voltage input
53	AVDD	—	Power supply terminal (+3.3V) (analog system)
54	BIAS	I (A)	Playback EFM asymmetry circuit constant current input
55	RFI	I (A)	Playback EFM RF signal input from the CXA2523AR (IC101)
56	AVSS	—	Ground terminal (analog system)
57	PDO	O (3)	Phase comparison output for clock playback analog PLL of the playback EFM Not used (open)
58	PCO	O (3)	Phase comparison output for master clock of the recording/playback EFM master PLL
59	FILI	I (A)	Filter input for master clock of the recording/playback master PLL
60	FILO	O (A)	Filter output for master clock of the recording/playback master PLL
61	CLTV	I (A)	Internal VCO control voltage input of the recording/playback master PLL
62	PEAK	I (A)	Light amount signal (RF/ABCD) peak hold input from the CXA2523AR (IC101)
63	BOTM	I (A)	Light amount signal (RF/ABCD) bottom hold input from the CXA2523AR (IC101)
64	ABCD	I (A)	Light amount signal (ABCD) input from the CXA2523AR (IC101)
65	FE	I (A)	Focus error signal input from the CXA2523AR (IC101)
66	AUX1	I (A)	Auxiliary signal (I3 signal/temperature signal) input from the CXA2523AR (IC101)
67	VC	I (A)	Middle point voltage (+1.65V) input from the CXA2523AR (IC101)
68	ADIO	O (A)	Monitor output of the A/D converter input signal Not used (open)
69	AVDD	—	Power supply terminal (+3.3V) (analog system)
70	ADRT	I (A)	A/D converter operational range upper limit voltage input terminal (fixed at “H” in this set)
71	ADRB	I (A)	A/D converter operational range lower limit voltage input terminal (fixed at “L” in this set)
72	AVSS	—	Ground terminal (analog system)
73	SE	I (A)	Sled error signal input from the CXA2523AR (IC101)
74	TE	I (A)	Tracking error signal input from the CXA2523AR (IC101)
75	AUX2	I (A)	Auxiliary signal input terminal Not used (fixed at “H”)
76	DCHG	I (A)	Connected to the +3.3V power supply
77	APC	I (A)	Error signal input for the laser automatic power control Not used (fixed at “L”)
78	ADFG	I	ADIP duplex FM signal (22.05 kHz \pm 1 kHz) input from the CXA2523AR (IC101)
79	FOCNT	O	Filter f0 control signal output to the CXA2523AR (IC101)
80	XLRF	O	Serial latch signal output to the CXA2523AR (IC101)
81	CKRF	O	Serial clock signal output to the CXA2523AR (IC101)
82	DTRF	O	Writing data output to the CXA2523AR (IC101)

* I (A) for analog input, O (3) for 3-state output, and O (A) for analog output in the column I/O.

Pin No.	Pin Name	I/O	Function
83	APCREF	O	Control signal output to the reference voltage generator circuit for the laser automatic power control
84	LDDR	O	PWM signal output for the laser automatic power control Not used (open)
85	TRDR	O	Tracking servo drive PWM signal (-) output to the BH6511FS (IC152)
86	TFDR	O	Tracking servo drive PWM signal (+) output to the BH6511FS (IC152)
87	DVDD	—	Power supply terminal (+3.3V) (digital system)
88	FFDR	O	Focus servo drive PWM signal (+) output to the BH6511FS (IC152)
89	FRDR	O	Focus servo drive PWM signal (-) output to the BH6511FS (IC152)
90	FS4	O	Clock signal (176.4 kHz) output terminal (X'tal system) Not used (open)
91	SRDR	O	Sled servo drive PWM signal (-) output to the BH6511FS (IC152)
92	SFDR	O	Sled servo drive PWM signal (+) output to the BH6511FS (IC152)
93	SPRD	O	Spindle servo drive PWM signal (-) output to the BH6511FS (IC152)
94	SPFD	O	Spindle servo drive PWM signal (+) output to the BH6511FS (IC152)
95	FGIN	I	Input terminal for the test (fixed at "L")
96	TEST1	I	
97	TEST2	I	
98	TEST3	I	
99	DVSS	—	Ground terminal (digital system)
100	EFMO	O	EFM signal output terminal when recording mode

• BD (MD) BOARD IC316 M30610MC-116FP (MD SYSTEM CONTROL)

Pin No.	Pin Name	I/O	Function
1,2	(JOG0, JOG1)	I	Encoder switch signal input terminal Not used (fixed at "H")
3,4	DAOUT1, DAOUT2	O	Not used (fixed at "L")
5	SQSY	I	Subcode Q sync (SCOR) input from the CXD2652AR (IC121)
6	REMCN	I	Remote control signal input
7	EMP	O	De-emphasis control signal output to the AK4520 (IC201)
8	BYTE	I	External data bus line byte select signal input terminal "L":16bit "H": 8bit (fixed at "L")
9	CNVSS	I	Processor mode select signal input terminal (fixed at "L")
10	XIN-T	I	Sub system clock input terminal Not used (fixed at "L")
11	(XOUT-T)	O	Sub sytem clock output terminal Not used (fixed at "L")
12	SYSTEM-RST	I	MD reset signal input from the M62016 (IC603)
13	XOUT	O	Main system clock signal output terminal
14	GND	—	Ground terminal
15	XIN	I	Main sytem clock signal input terminal
16	+3V	—	Power supply terminal (+3.3V)
17	NMI	—	Connecting to power supply
18	AMUTE	—	Not used (fixed at "L")
19	PWR-DWN	O	Power down detect signal output to the LA5620 (IC570)
20	DQSY	I	Digital in U-bit CD format subcode Q sync (SCOR) input from theCXD2652SAR (IC121)
21	STB	I	Stand-by signal input terminal Not used (fixed at "L")
22	DA-RST	I	D/A converter reset signal input terminal Not used (fixed at "L")
23	XINT	I	Interrupt status input from the CXD2652AR (IC121)
24	DA-EN	O	D/A converter enable signal output to the AK4520 (IC201)
25	AD-EN	O	A/D converter enable signal output to the AK4520 (IC201)
26	MEC-BUSY	O	Mecha-busy signal output to the master control (IC601)
27	FLCS	O	Display clear signal output terminal Not used (fixed at "L")
28	FLCLK	O	Display data clock signal output terminal Not used (fixed at "L")
29	—————	—	Not used (fixed at "L")
30	FLDATA	O	Display data signal output terminal Not used (fixed at "L")
31	TXD	O	MD control data signal output to the master control (IC601)
32	RXD	I	MD control data signal input to the master control (IC601)
33	CLK	I	MD control data clock signal input to the master control (IC601)
34	MAS-BUSY	I	Master-busy signal input from the master control (IC601)
35	SWDT	O	Writing data signal output to the CXD2652AR (IC121)
36	SRDT	I	Reading data signal input from the CXD2652AR (IC121)
37	SCLK	O	Serial clock signal output to the CXD2652AR (IC121)
38	XLAT	O	Serial latch signal output to the CXD2652AR (IC121)
39	—————	O	Clock signal output terminal Not used (fixed at "L")
40	DIG-RST	O	Reset signal output enable signal output to the CXD2652AR (IC121)
41	SENS	I	Status (SENSE) input from the CXD2652AR (IC121)
42	SCTX	O	Recording data output enable signal output to the CXD2652AR (IC121)
43	XINT	O	Not used (fixed at "L")
44	WRPWR	O	Laser power selection signal output to the CXD2652AR (IC121)
45	MNT3	I	Monitor 3 signal input from the CXD2652AR (IC121)
46	MNT2	I	Monitor 2 signal input from the CXD2652AR (IC121)
47	MNT1	I	Track jump detection signal input from the CXD2652AR (IC121)
48	MNTO	I	Focus OK signal input from the CXD2652AR (IC121)
49	LDON	O	Laser diode ON signal output terminal

Pin No.	Pin Name	I/O	Function
50	MOD	O	HF module ON signal output terminal
51	LDIN	O	MD loading-in signal output to LB1830M (IC153)
52	LDOUT	O	MD loading-out signal output to LAB1830M (IC153)
53	LD-LOW	O	Loading motor voltage control signal output to the loading motor driver
54	PROTECT	I	MD PROTECT switch (S683) detect signal input terminal
55	REFLECT	I	MD REFLECT switch (S682) detect signal input terminal
56	PACK-IN	I	Not used
57	PACK-OUT	I	MD PACK OUT switch (S686) detect signal input terminal
58	CHUCK-IN	I	MD CHUCKING IN switch (S685) detect signal input terminal
59	LIMIT-IN	I	MD LIMIT IN switch (S681) detect signal input terminal
60	REC. P	I	MD REC POSITION switch (S688) detect signal input terminal
61	PB. P	I	MD PB POSITION switch (S687) detect signal input terminal
62	+5V	—	Power supply (+5V)
63	—————	—	Not used (fixed at “L”)
64	GND	—	Ground terminal
65 to 72	—————	—	Connect terminal 65 to 72 Not used (fixed at “L”)
73 to 78	—————	—	Not used (fixed at “L”)
79	SDA	I/O	Tow-way data bus for the EEPROM (IC171)
80	SCL	O	Clock signal output to the EEPROM (IC171)
81, 82	—————	—	Not used (fixed at “L”)
83	POWER	—	Conenct terminal 83 to 85 Not used (fixed at “L”)
84, 85	—————	—	
86, 87	—————	—	Not used (fixed at “L”)
88 to 90	—————	—	Connect terminal 88 to 90 Not used (fixed at “L”)
91 to 93	KEY0, KEY1, KEY2	—	Connect terminal 91 to 93 Not used (fixed at “H”)
94	—————	—	Not used (fixed at “L”)
95	SOURCE	—	Not used (fixed at “L”)
96	AVSS	—	Ground terminal
97	—————	—	Not used (fixed at “L”)
98	VREF5V	—	Power supply (+5V)
99	3.3V	—	Power supply (+3.3V)
100	—————	—	Not used (fixed at “L”)

• MAIN BOARD (1/3) IC601 μ PD78078GF-062-3BA (MASTER CONTROL)

Pin No.	Pin Name	I/O	Function
1 to 3	VER	I	Destination setting terminal
4	VER	I	Destination setting terminal Not used (open)
5 to 7	(NC)	—	Not used
8	(NC)	—	Not used (open)
9	IC	—	Connecting to ground
10	X2	O	Main system clock output terminal (5 MHz)
11	X1	I	Main system clock input terminal (5 MHz)
12	VDD	—	Power supply terminal (+5V)
13	XT2	O	Sub system clock output terminal (32 kHz)
14	XT1	I	Sub system clock input terminal (32 kHz)
15	RESET	I	System reset signal input from the reset signal generator (IC602)
16	AU-BUS IN	I	AU-BUS signal input terminal
17	AU-BUS OUT	O	AU-BUS signal output terminal
18	ENC/A	I	Encoder volume signal A input from the master volume (S901)
19	ENC/B	I	Encoder volume signal B input from the master volume (S901)
20	RDS/CLK	I	RDS clock signal input from the RDS demodulator (IC1500)
21	RDS/DATA	I	RDS data signal input from the RDS demodulator (IC1500)
22	SCOR (BD)	I	Sub-code sync S0, S1 detect signal input from the digital signal processor (IC103)
23	AVDD	—	Power supply terminal (+5V) (for A/D converter)
24	AVREF0	—	Reference voltage input terminal (+5V) (for A/D converter)
25	KEY0	I	Key input terminal (A/D input) POWER key (S902) input
26	KEY1	I	Key input terminal (A/D input) ■ (CD), ► (CD), ≡ (CD), ■ (MD), ► (MD), ≡ (MD) keys (S903 to S908) input
27	KEY2	I	Key input terminal (A/D input) FUNCTION, ►►►► +, TUNER/BAND, ◀◀◀◀ -, ● REC, CD-MD SYNC, REPEAT STEREO/MONO, PLAY MODE TUNING MODE (S909 to S916) input
28 to 30	(NC)	—	Not used
31	RTS (TO MD. CTS) MASTER BUSY	O	Master-busy signal output to the MD system control (IC316)
32	MD-POWER	O	MD power on/off signal output to the MD power regulator (IC570)
33	AVSS	—	Ground terminal (for A/D converter)
34	POWER ON	I	System power on signal input terminal
35	MD OEM/REST	O	MD reset signal output terminal
36	AVREF1	I	Reference voltage input terminal (+5V) (for A/D converter)
37	RXD (TO MD. TXD) RXD	I	MD control data signal input from the MD system control (IC316)
38	TXD (TO MD. RXD) TXD	O	MD control data signal output to the MD system control (IC316)
39	MD-CLK	O	MD control data clock signal output to the MD system control (IC316)
40	VSS	—	Ground terminal
41	CTS (TO MD. RTS) MECHA BUSY	I	Mecha-busy signal input from the MD system control (IC316)
42	FL/DRIV DATA	O	Display data signal output to the fluorescent indicator drive (IC901)
43	FL/DRIV CLOCK	O	Display data clock signal output to the fluorescent indicator drive (IC901)
44	FL/DRIV CS	O	Display clear signal output to the fluorescent indicator drive (IC901) "L": data output
45	FL/DRIVE RESET	O	Display reset signal output to the fluorescent indicator drive (IC901) "L": reset
46	BD SUBQ	I	Sub-code Q data signal input from the CXD2507AQ (IC103)
47	(NC)	—	Not used (open)
48	BD SQCLK	O	Sub-code Q data reading clock signal output to the CXD2507AQ (IC103)
49	BD CLOCK	O	Serial data clock signal output to the CXD2507AQ (IC103)

Pin No.	Pin Name	I/O	Function
50	BD DATA	O	Serial data output to the CXD2507AQ (IC103)
51	XLT	O	Serial data latch pulse signal output to the CXD2507AQ (IC103)
52	PRGL (DF. LAT)	O	Serial data latch pulse signal output to the PCM1710U (IC104)
53	SENCE	I	Internal status (SENSE) signal input from the CXD2507AQ (IC103)
54	ADJ	I	Test mode input terminal "H": normal (fixed at "H" in this set)
55	IN-SW	I	Disc tray close complete signal input terminal "L": Completed
56	OUT-SW	I	Disc tray open complete signal input terminal "L" Completed
57	LOAD-OUT	O	Disc tray loading out signal output to the motor driver (IC801)
58	LOAD-IN	O	Disc tray loading in signal output to the motor driver (IC801)
59	FOCUS-SW	O	Focus gain selection switch signal output terminal "L": normal "H": down
60	BD-REST	O	BD block reset signal output terminal "L": reset
61	CD-POWER	O	CD power on/off signal output to the CD power regulator (Q561, 562)
62	ST-POWER	O	ST power on/off signal output terminal Not used (open)
63	D. IN. SELECT	O	Optical/CD select signal output terminal "H": optical "L": CD
64, 65	(NC)	—	Not used
66	LED-CD. DISC	O	CD INDICATOR LED (D908) drive signal output terminal
67	LED-MD. DISC	O	MD INDICATOR LED (D905) drive signal output terminal
68	LED-MD. REC	O	● LED (D904) drive signal output terminal
69	LED-CD. PAUSE	O	▬ (CD) LED (D907) drive signal output terminal
70	LED-CD. PLAY	O	▶ (CD) LED (D906) drive signal output terminal
71	VSS	—	Ground terminal
72	LED-MD. PAUSE	O	▬ (MD) LED (D903) drive signal output terminal
73	LED-MD. PLAY	O	▶ (MD) LED (D902) drive signal output terminal
74	DBFB	O	DBFB on/off signal output terminal "L": on
75	RECOU. MUTE	O	Rec mute (tape) signal output terminal "L": mute
76	MUTE	O	Mute signal output terminal
77	ATT/6DB	O	Tape input level attenuate signal output terminal
78	SOUND/IC DATA	O	Graphic equalizer data signal output to the M62428FP (IC701)
79	SOUND/IC CLOCK	O	Graphic equalizer data clock signal output to the M62428FP (IC701)
80	SOUND/IC LAT	O	Graphic equalizer data latch pulse signal output to the M62428FP (IC701)
81	(GND)	—	Ground terminal
82	ST STEREO	I	Stereo detection signal input from the tuner
83	ST TUNED	I	Tuned detection signal input from the tuner
84	ST DATA-IN	I	Data signal input from the tuner
85	ST DATA-OUT	O	Data signal output to the tuner
86	ST CLOCK	O	Data transfer clock signal output to the tuner
87	ST CE	O	Chip enable signal output to the tuner
88	ST MUTE	O	Mute signal output to the tuner
89	FM/AM SELECT	O	FM/AM select signal output Not used (open)
90	SIRCUS	I	Remote control signal input from the remote control receiver (IC902)
91	(EWS STBY OK)	—	Not used (open)
92	(EWS NOW)	—	Connecting to ground
93	FAN SPEED	O	Fan speed control signal output terminal Not used (open)
94	FAN STOP	O	Fan on/off signal output terminal Not used (open)
95 to 99	(NC)	—	Connecting to ground
100	AC-CUT	I	System reset signal input from the reset signal generator (IC602)

SECTION 7 EXPLODED VIEWS

NOTE:

- -XX and -X mean standardized parts, so they may have some difference from the original one.
- Color Indication of Appearance Parts
Example:
KNOB, BALANCE (WHITE) . . . (RED)
 ↑ ↑
 Parts Color Cabinet's Color
- Abbreviation
AED : North European HK : Hong Kong
CND : Canadian MY : Malaysia
G : German SP : Singapore

HK : Hong Kong

- Items marked “*” are not stocked since they are seldom required for routine service. Some delay should be anticipated when ordering these items.
- The mechanical parts with no reference number in the exploded views are not supplied.
- Hardware (# mark) list is given in the last of the electrical parts list.

The components identified by mark Δ or dotted line with mark Δ are critical for safety. Replace only with part number specified.

Les composants identifiés par une marque Δ sont critiques pour la sécurité. Ne les remplacer que par une pièce portant le numéro spécifié.

(1) FRONT PANEL SECTION

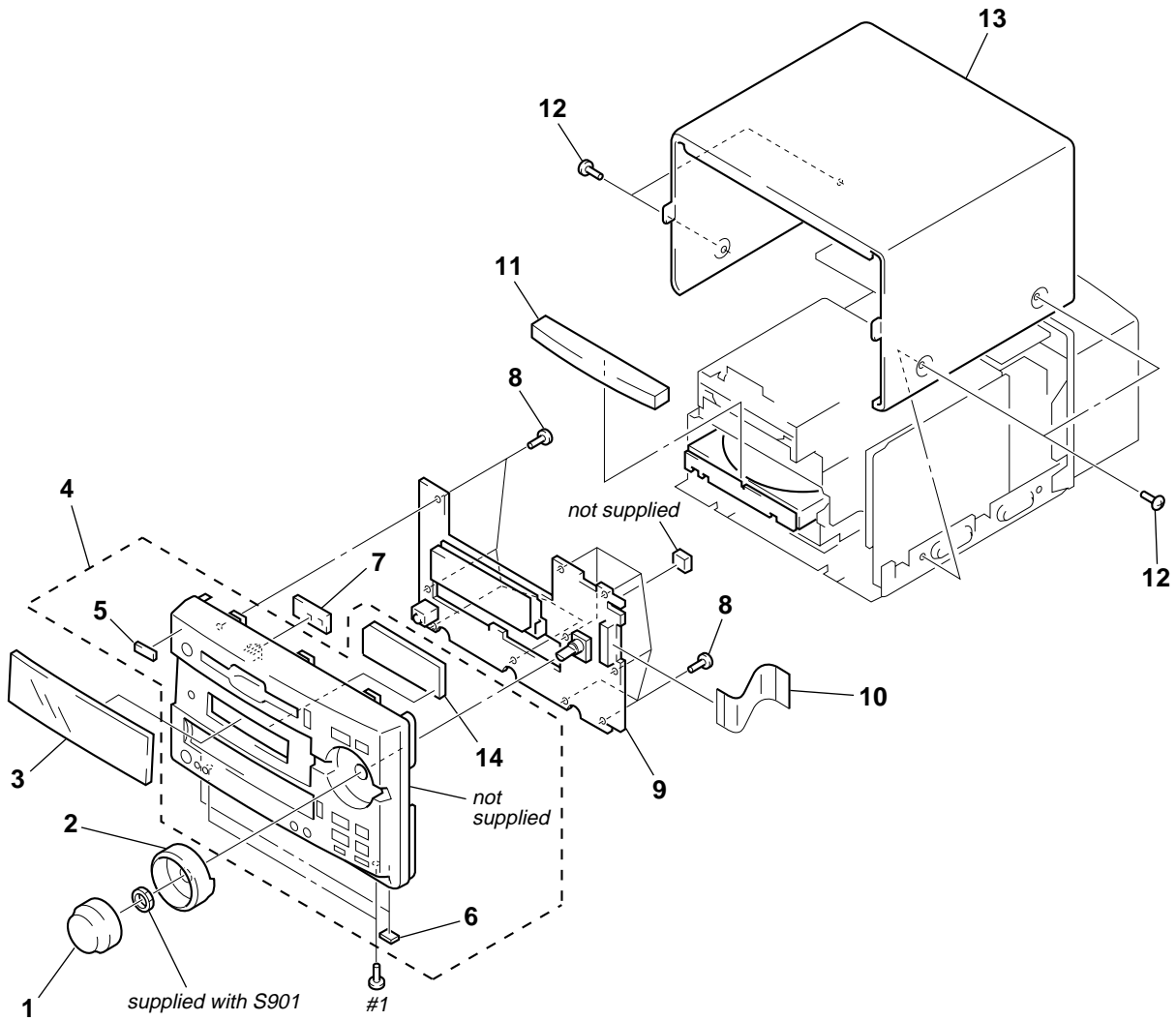

Ref. No.	Part No.	Description	Remark	Ref. No.	Part No.	Description	Remark
1	X-4949-008-1	KNOB (VOL) ASSY		* 7	1-666-899-11	MD-LED BOARD	
2	4-993-862-01	RING (VOL)		8	4-951-620-01	SCREW (2.6X8), +BVTP	
3	4-993-863-01	WINDOW (M3) (CND, MY, SP, HK)		* 9	A-4403-402-A	PANEL BOARD, COMPLETE	
3	4-993-863-11	WINDOW (M3) (AEP, UK, G, AED)		10	1-782-793-11	WIRE (FLAT TYPE) (23 CORE)	
4	X-4948-965-1	PANEL ASSY, FRONT (AEP, UK, G, AED)		11	4-993-851-01	PANEL (CD), LOADING	
4	X-4949-259-3	PANEL ASSY, FRONT (CND, MY, SP, HK)		12	3-363-099-11	SCREW (CASE 3 TP2)	
5	4-962-708-01	EMBLEM (4-A), SONY		* 13	4-993-842-01	CASE	
* 6	4-930-336-71	FOOT (FELT)		14	4-993-852-01	FILTER (FL)	

(2) CHASSIS SECTION

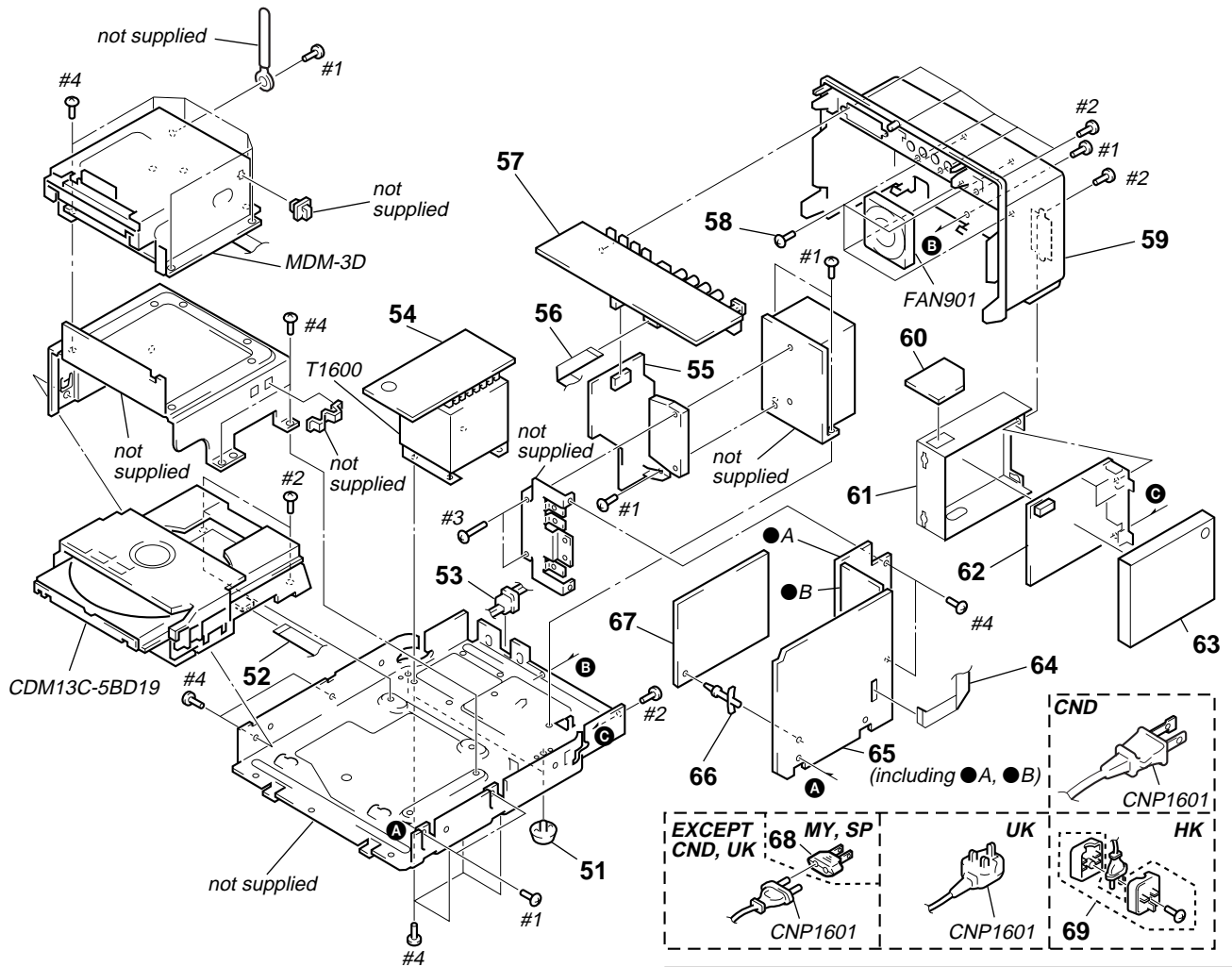

The components identified by mark \triangle or dotted line with mark \triangle are critical for safety. Replace only with part number specified.

Les composants identifiés par une marque \triangle sont critiques pour la sécurité. Ne les remplacer que par une pièce portant le numéro spécifié.

Ref. No.	Part No.	Description	Remark	Ref. No.	Part No.	Description	Remark
51	4-993-867-01	FOOT (8)		62	1-693-387-21	TUNER (FM/MW/LW) (AEP, UK, G, AED)	
52	1-782-990-11	WIRE (FLAT TYPE) (19 CORE)		* 63	4-984-204-11	PLATE (ST-B), SHIELD	
53	3-703-244-00	BUSHING (2104), CORD		64	1-783-213-11	WIRE (FLAT TYPE) (15 CORE): BEND (10 cm)	
* 54	1-666-904-11	TRANSFORMER BOARD		* 65	A-4403-408-A	MAIN BOARD, COMPLETE (AEP, UK, G, AED)	
* 55	A-4403-410-A	POWER AMP BOARD, COMPLETE (AEP, UK, G, AED)		* 65	A-4403-415-A	MAIN BOARD, COMPLETE (MY, SP, HK)	
* 55	A-4403-417-A	POWER AMP BOARD, COMPLETE (MY, SP, HK)		* 65	A-4407-383-A	MAIN BOARD, COMPLETE (CND)	
* 55	A-4407-385-A	POWER AMP BOARD, COMPLETE (CND)		* 66	4-924-098-91	HOLDER, PC BOARD	
56	1-782-991-11	WIRE (FLAT TYPE) (15 CORE) (10 cm)		* 67	A-4403-412-A	AUDIO BOARD, COMPLETE (AEP, UK, G, AED)	
* 57	A-4403-414-A	JACK BOARD, COMPLETE (AEP, UK, G, AED)		* 67	A-4403-419-A	AUDIO BOARD, COMPLETE (MY, SP, HK)	
* 57	A-4403-421-A	JACK BOARD, COMPLETE (MY, SP, HK)		* 67	A-4407-387-A	AUDIO BOARD, COMPLETE (CND)	
* 57	A-4407-389-A	JACK BOARD, COMPLETE (CND)		\triangle 68	1-569-008-11	ADAPTOR, CONVERSION 2P (MY, SP)	
58	4-985-672-01	SCREW (+PTPWHM2.6), FLOATING		\triangle 69	1-770-019-11	ADAPTOR, CONVERSION PLUG 3P (HK)	
* 59	4-993-849-11	PANEL, BACK (AEP, UK, G, AED)		\triangle CNP1601 1-690-609-71		CORD, POWER (CND)	
* 59	4-993-849-21	PANEL, BACK (MY, SP, HK)		\triangle CNP1601 1-696-570-21		CORD, POWER (UK)	
* 59	4-993-849-31	PANEL, BACK (CND)		\triangle CNP1601 1-769-744-11		CORD, POWER (EXCEPT CND, UK)	
* 60	1-666-905-11	ST TERMINAL BOARD		FAN901	1-698-997-11	FAN, DC	
* 61	4-984-203-21	PLATE (ST-A), SHIELD		\triangle T1600	1-431-497-11	TRANSFORMER, POWER (AEP, UK, G, AED)	
62	1-233-544-21	ENCAPSULATED COMPONENT (CND)		\triangle T1600	1-431-498-11	TRANSFORMER, POWER (MY, SP, HK)	
62	1-233-546-21	ENCAPSULATED COMPONENT (MY, SP, HK)		\triangle T1600	1-431-756-11	TRANSFORMER, POWER (CND)	

**(3) MD MECHANISM DECK SECTION-1
(MDM-3D)**

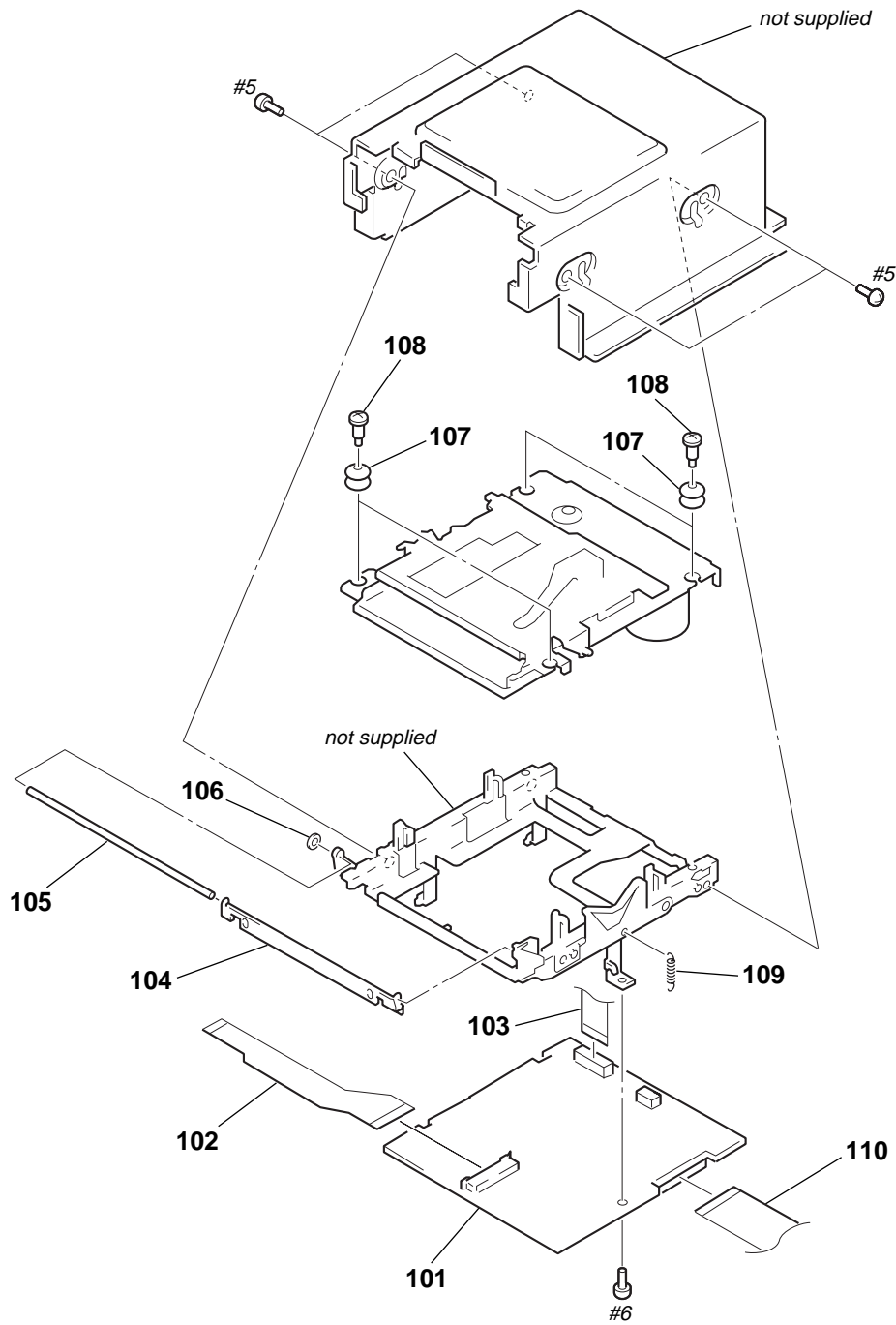

Ref. No.	Part No.	Description	Remark	Ref. No.	Part No.	Description	Remark
* 101	A-4699-808-A	BD (MD) BOARD, COMPLETE		106	4-986-959-01	WASHER, STOPPER	
102	1-660-966-11	OP RELAY FLEXIBLE BOARD		107	4-987-327-01	INSULATOR	
103	1-782-683-11	WIRE (FLAT TYPE) (14 CORE)		108	4-628-167-01	SCREW, STEP	
104	X-4948-722-1	SHUTTER ASSY		109	4-987-910-01	SPRING (O/C), TENSION	
105	4-987-736-01	SHAFT (SHUTTER)		110	1-783-113-11	WIRE (FLAT TYPE) (25 CORE)	

**(4) MD MECHANISM DECK SECTION-2
(MDM-3D)**

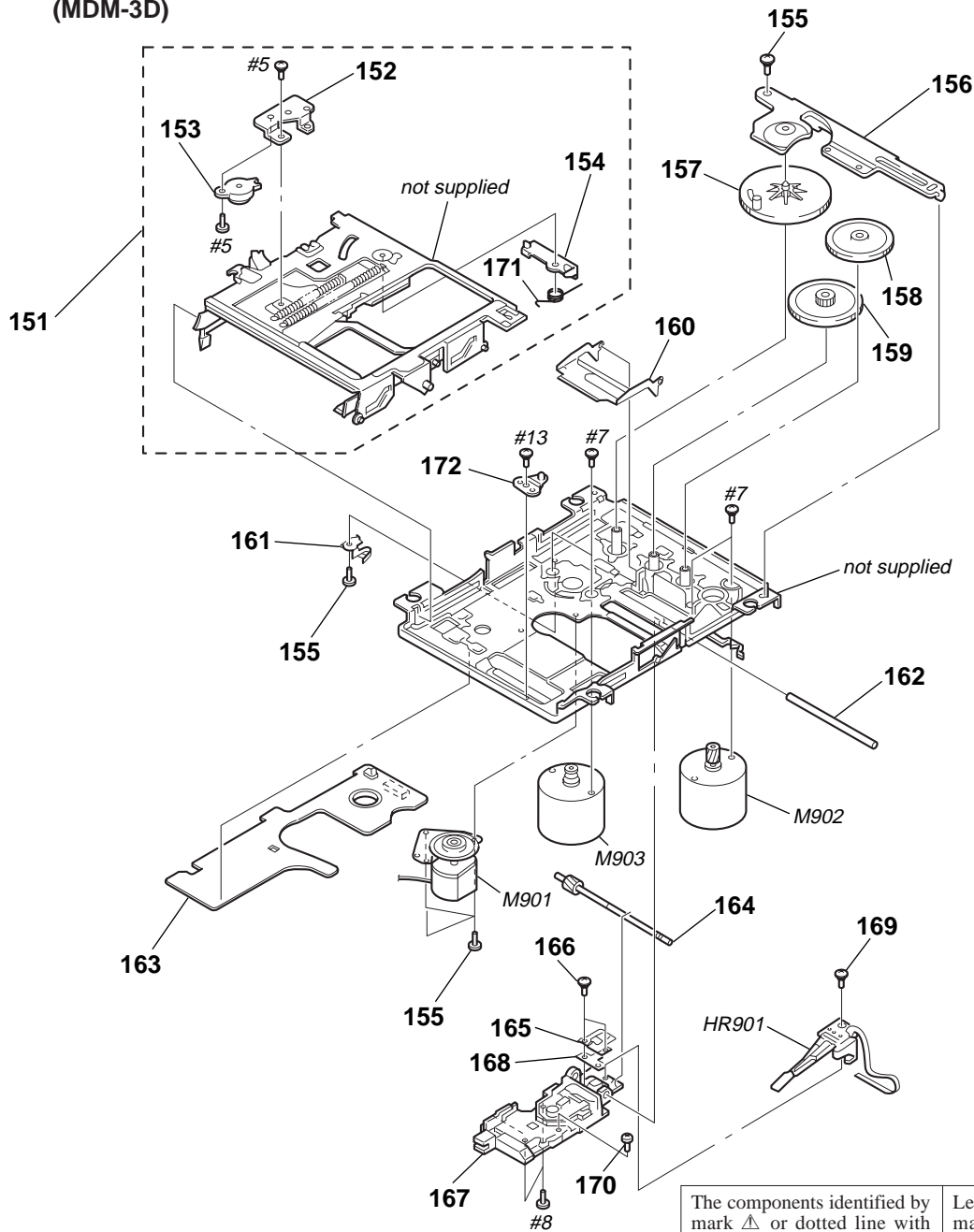

<p>The components identified by mark \triangle or dotted line with mark \triangle are critical for safety. Replace only with part number specified.</p>	<p>Les composants identifiés par une marque \triangle sont critiques pour la sécurité. Ne les remplacer que par une pièce portant le numéro spécifié.</p>
---	--

Ref. No.	Part No.	Description	Remark	Ref. No.	Part No.	Description	Remark
151	A-4672-138-A	SLIDER COMPLETE ASSY		164	A-3304-200-A	SCREW ASSY, LEAD	
* 152	4-983-439-01	BRACKET (DAMPER)		165	4-963-914-02	RACK (INSERTER)	
153	3-953-235-01	DAMPER, OIL		166	3-366-890-11	SCREW (M1.4)	
* 154	4-983-437-01	SLIDER (CAM)		\triangle 167	8-583-028-02	OPTICAL PICK-UP KMS-260A/J1N (for MD)	
155	3-342-375-11	SCREW (M1.7X1.4), SPECIAL		168	4-987-061-01	SPACER (RACK)	
156	4-979-890-13	RETAINER (GEAR)		169	4-988-560-01	SCREW (+P 1.7X6)	
157	4-979-898-01	GEAR (LB)		170	4-955-841-11	SCREW	
158	4-979-899-01	GEAR (LC)		171	4-979-914-01	SPRING (CLV), TORSION	
159	4-979-897-01	GEAR (LA)		* 172	4-983-511-02	PIN (OUTSERT)	
160	4-979-885-01	LEVER (HEAD UP)		HR901	1-500-396-11	HEAD, OVER LIGHT (RF325-74A)	
161	4-979-906-11	SPRING (LEAD SCREW)		M901	A-4672-135-A	MOTOR ASSY, SPINDLE	
162	4-984-556-01	SHAFT (MAIN SHAFT)		M902	A-4672-133-A	MOTOR ASSY, SLED	
* 163	1-667-719-11	SW BOARD		M903	A-4672-134-A	MOTOR ASSY, LOADING (MD)	

(5) CD MECHANISM DECK SECTION-1
(CDM13C-5BD19)

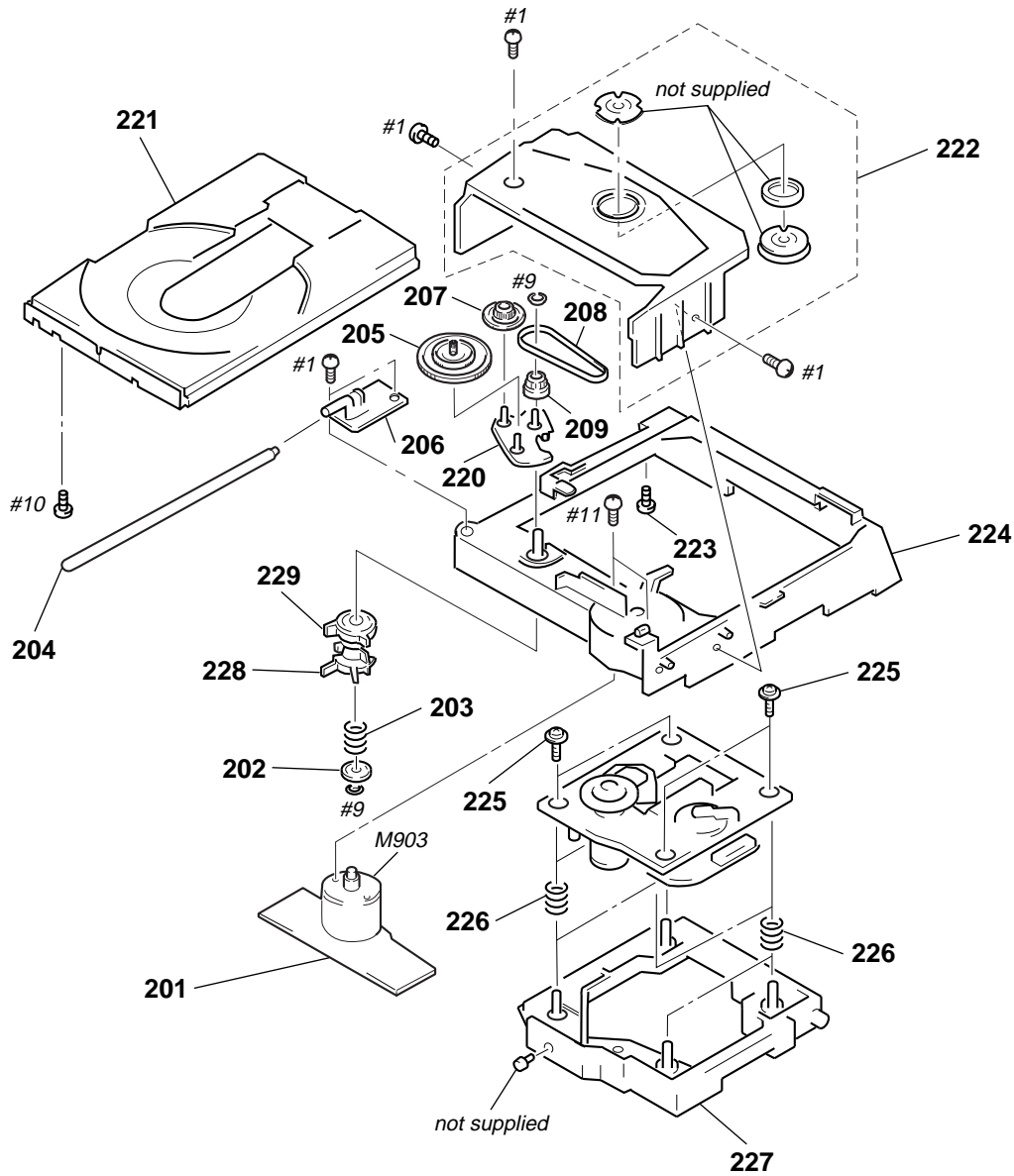

Ref. No.	Part No.	Description	Remark	Ref. No.	Part No.	Description	Remark
* 201	1-634-461-11	LOADING BOARD		221	4-944-012-01	TABLE, DISC	
202	4-927-654-01	WASHER (LIMITER)		222	A-4604-752-A	HOLDER (MG) ASSY	
203	3-659-338-00	SPRING, COMPRESSION		* 223	4-917-583-21	BRACKET, YOKE	
204	4-929-764-01	SHAFT (TABLE GUIDE)		* 224	X-4946-208-2	CHASSIS (MD) ASSY	
205	4-927-620-01	GEAR (P)		225	4-933-134-01	SCREW (+PTPWH M2.6X6)	
206	4-944-006-11	BEARING		226	4-958-593-01	SPRING (BU), COMPRESSION	
207	4-927-628-01	GEAR (C)		227	4-929-747-01	HOLDER (BU)	
208	4-927-649-01	BELT		228	4-929-727-01	CAM (A)	
209	4-929-724-01	PULLEY (B)		229	4-929-729-01	CAM (B)	
220	X-4947-265-1	ARM ASSY, SWING		M903	A-4608-362-A	MOTOR (L) ASSY (LOADING) (CD)	

**(6) CD MECHANISM DECK SECTION-2
(CDM13C-5BD19)**

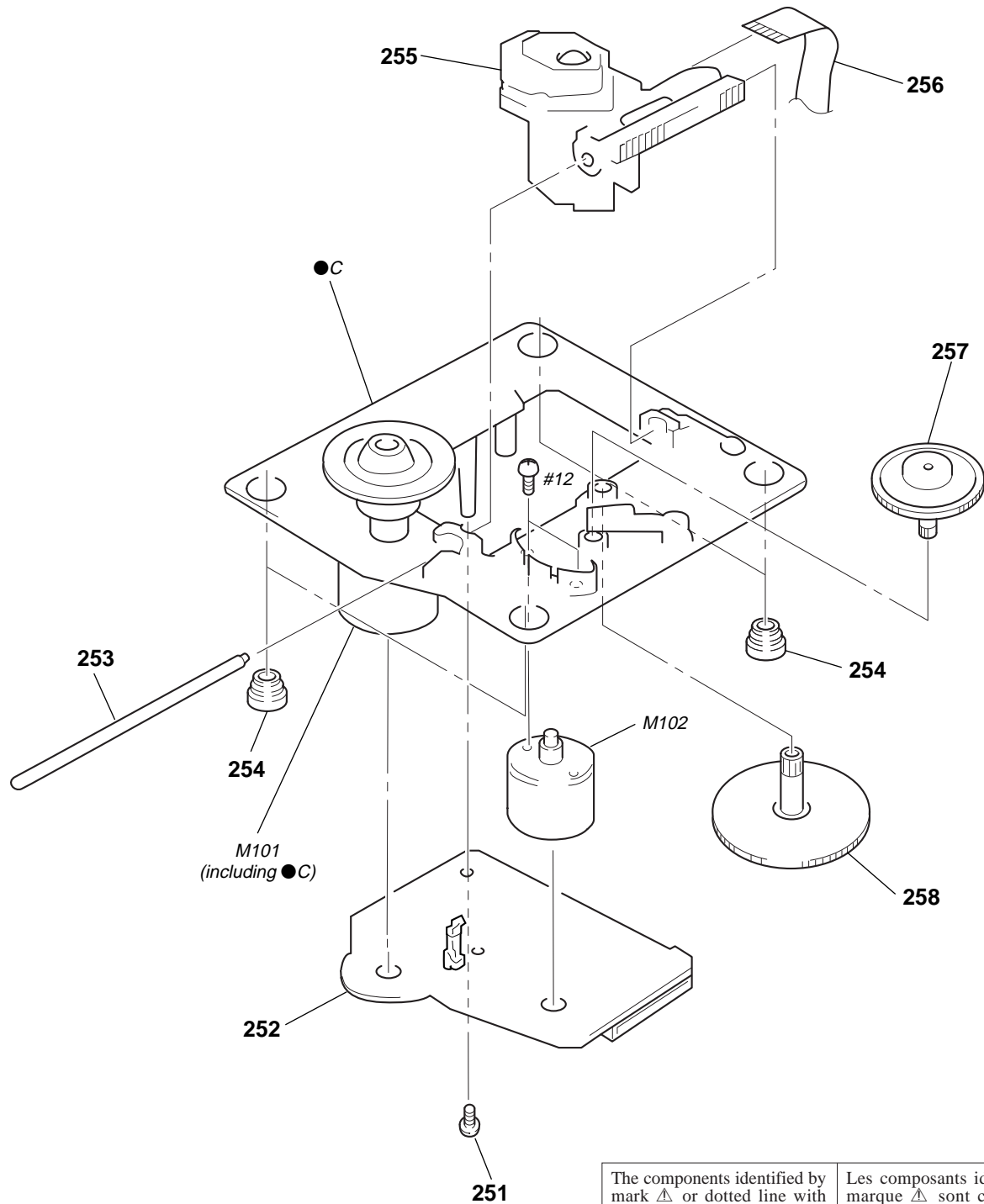

<p>The components identified by mark Δ or dotted line with mark Δ are critical for safety. Replace only with part number specified.</p>	<p>Les composants identifiés par une marque Δ sont critiques pour la sécurité. Ne les remplacer que par une pièce portant le numéro spécifié.</p>
---	---

Ref. No.	Part No.	Description	Remark	Ref. No.	Part No.	Description	Remark
251	4-951-620-01	SCREW (2.6X8), +BVTP		256	1-769-069-11	WIRE (FLAT TYPE) (16 CORE)	
* 252	A-4673-402-A	BD (CD) BOARD, COMPLETE		257	4-917-567-01	GEAR (M)	
253	4-917-565-01	SHAFT, SLED		258	4-917-564-01	GEAR (P), FLATNESS	
254	4-951-940-01	INSULATOR (BU)		M101	X-4917-523-4	BASE (OUTSART) ASSY (SPINDLE)	
Δ 255	8-848-367-11	OPTICAL PICK-UP KSS-213B/K-N (for CD)		M102	X-4917-504-1	MOTOR ASSY (SLED)	

**SECTION 8
ELECTRICAL PARTS LIST**

NOTE:

- Due to standardization, replacements in the parts list may be different from the parts specified in the diagrams or the components used on the set.
- -XX and -X mean standardized parts, so they may have some difference from the original one.
- **RESISTORS**
All resistors are in ohms.
METAL: Metal-film resistor.
METAL OXIDE: Metal oxide-film resistor.
F: nonflammable
- **Abbreviation**
AED : North European
CND : Canadian
G : German
HK : Hong Kong
MY : Malaysia
SP : Singapore

- Items marked “*” are not stocked since they are seldom required for routine service.
Some delay should be anticipated when ordering these items.
- **SEMICONDUCTORS**
In each case, u: μ , for example:
uA. . : μ A. . uPA. . : μ PA. .
uPB. . : μ PB. . uPC. . : μ PC. .
uPD. . : μ PD. .
- **CAPACITORS**
uF: μ F
- **COILS**
uH: μ H

The components identified by mark Δ or dotted line with mark Δ are critical for safety.
Replace only with part number specified.

Les composants identifiés par une marque Δ sont critiques pour la sécurité.
Ne les remplacer que par une pièce portant le numéro spécifié.

When indicating parts by reference number, please include the board.

Ref. No.	Part No.	Description	Remark
*	A-4403-412-A	AUDIO BOARD, COMPLETE (AEP, UK, G, AED)	
*	A-4403-419-A	AUDIO BOARD, COMPLETE (MY, SP, HK)	
*	A-4407-387-A	AUDIO BOARD, COMPLETE (CND)	

< CAPACITOR >			
C701	1-126-163-11	ELECT	4.7uF 20% 50V
C702	1-126-163-11	ELECT	4.7uF 20% 50V
C703	1-126-163-11	ELECT	4.7uF 20% 50V
C704	1-126-163-11	ELECT	4.7uF 20% 50V
C705	1-126-163-11	ELECT	4.7uF 20% 50V
C706	1-136-165-00	FILM	0.1uF 5% 50V
C707	1-124-464-11	ELECT	0.22uF 20% 50V
C708	1-130-473-00	MYLAR	0.0015uF 5% 50V
C709	1-126-160-11	ELECT	1uF 20% 50V
C712	1-162-294-31	CERAMIC	0.001uF 10% 50V
C713	1-124-589-11	ELECT	47uF 20% 16V
C714	1-136-165-00	FILM	0.1uF 5% 50V
C715	1-136-165-00	FILM	0.1uF 5% 50V
C716	1-124-261-00	ELECT	10uF 20% 50V
C717	1-126-163-11	ELECT	4.7uF 20% 50V
C718	1-162-290-31	CERAMIC	470PF 10% 50V
C719	1-124-589-11	ELECT	47uF 20% 16V
C720	1-124-589-11	ELECT	47uF 20% 16V
C731	1-130-475-00	MYLAR	0.0022uF 5% 50V
C743	1-124-589-11	ELECT	47uF 20% 16V
C751	1-126-163-11	ELECT	4.7uF 20% 50V
C752	1-126-163-11	ELECT	4.7uF 20% 50V
C753	1-126-163-11	ELECT	4.7uF 20% 50V
C754	1-126-163-11	ELECT	4.7uF 20% 50V
C755	1-126-163-11	ELECT	4.7uF 20% 50V
C756	1-136-165-00	FILM	0.1uF 5% 50V
C757	1-124-464-11	ELECT	0.22uF 20% 50V
C758	1-130-473-00	MYLAR	0.0015uF 5% 50V
C759	1-126-160-11	ELECT	1uF 20% 50V
C762	1-124-261-00	ELECT	10uF 20% 50V
C763	1-130-477-00	MYLAR	0.0033uF 5% 50V
C764	1-136-165-00	FILM	0.1uF 5% 50V
C765	1-136-165-00	FILM	0.1uF 5% 50V
C766	1-124-261-00	ELECT	10uF 20% 50V
C767	1-126-163-11	ELECT	4.7uF 20% 50V
C768	1-162-290-31	CERAMIC	470PF 10% 50V

Ref. No.	Part No.	Description	Remark
C769	1-162-294-31	CERAMIC	0.001uF 10% 50V
C781	1-130-475-00	MYLAR	0.0022uF 5% 50V
C1501	1-124-589-11	ELECT	47uF 20% 16V (AEP, UK, G, AED)
C1502	1-164-159-11	CERAMIC	0.1uF 50V (AEP, UK, G, AED)
C1503	1-162-157-11	ELECT	10uF 20% 16V (AEP, UK, G, AED)
C1504	1-162-291-31	CERAMIC	560PF 10% 50V (AEP, UK, G, AED)
C1505	1-126-157-11	ELECT	10uF 20% 16V (AEP, UK, G, AED)
C1506	1-124-257-00	ELECT	2.2uF 20% 50V (AEP, UK, G, AED)
C1507	1-102-518-11	CERAMIC	33PF 5% 50V (AEP, UK, G, AED)
C1508	1-162-288-31	CERAMIC	330PF 10% 50V (AEP, UK, G, AED)
C1509	1-102-518-11	CERAMIC	33PF 5% 50V (AEP, UK, G, AED)
C1510	1-162-306-11	CERAMIC	0.01uF 20% 16V (AEP, UK, G, AED)
C1511	1-162-291-31	CERAMIC	560PF 10% 50V (AEP, UK, G, AED)
C1512	1-162-306-11	CERAMIC	0.01uF 20% 16V (AEP, UK, G, AED)
C1513	1-162-301-11	CERAMIC	1500PF 20% 16V (AEP, UK, G, AED)
C1515	1-162-600-11	CERAMIC	4700PF 20% 16V (AEP, UK, G, AED)
< CONNECTOR >			
CN701	1-779-819-11	CONNECTOR, BOARD TO BOARD 14P	
CN702	1-779-819-11	CONNECTOR, BOARD TO BOARD 14P	
< DIODE >			
D701	8-719-911-19	DIODE 1SS119	
D1501	8-719-911-19	DIODE 1SS119 (AEP, UK, G, AED)	
< IC >			
IC701	8-759-439-30	IC M62428FP	
IC702	8-759-634-51	IC M5218AP	
IC1500	8-759-450-87	IC BU1922F (AEP, UK, G, AED)	
IC1501	8-759-636-55	IC M5218AFP (AEP, UK, G, AED)	

AUDIO

BD (CD)

Ref. No.	Part No.	Description	Remark	Ref. No.	Part No.	Description	Remark
		< COIL >		R1509	1-249-429-11	CARBON 10K	5% 1/4W (AEP, UK, G, AED)
L1501	1-410-521-11	INDUCTOR 100uH (AEP, UK, G, AED)				< VIBRATOR >	
		< TRANSISTOR >		X1501	1-579-900-21	VIBRATOR, CRYSTAL (4.332MHz)	(AEP, UK, G, AED)
Q701	8-729-119-78	TRANSISTOR 2SC403SP-51		*****			
Q702	8-729-141-30	TRANSISTOR 2SC3623A-LK					
Q703	8-729-422-57	TRANSISTOR UN4111					
Q751	8-729-119-78	TRANSISTOR 2SC403SP-51		*	A-4673-402-A	BD (CD) BOARD, COMPLETE	*****
Q752	8-729-141-30	TRANSISTOR 2SC3623A-LK					
		< RESISTOR >				<CAPACITOR>	
R702	1-249-433-11	CARBON 22K	5% 1/4W	C101	1-126-607-11	ELECT CHIP 47uF	20% 4V
R703	1-247-903-00	CARBON 1M	5% 1/4W	C102	1-163-275-11	CERAMIC CHIP 0.001uF	5% 50V
R704	1-249-429-11	CARBON 10K	5% 1/4W	C103	1-164-346-11	CERAMIC CHIP 1uF	16V
R705	1-247-843-11	CARBON 3.3K	5% 1/4W	C105	1-163-038-00	CERAMIC CHIP 0.1uF	25V
R706	1-247-885-00	CARBON 180K	5% 1/4W	C106	1-164-695-11	CERAMIC CHIP 0.0022uF	5% 50V
R707	1-249-425-11	CARBON 4.7K	5% 1/4W	C107	1-164-695-11	CERAMIC CHIP 0.0022uF	5% 50V
R708	1-249-421-11	CARBON 2.2K	5% 1/4W	C108	1-164-232-11	CERAMIC CHIP 0.01uF	50V
R709	1-247-895-00	CARBON 470K	5% 1/4W	C109	1-164-232-11	CERAMIC CHIP 0.01uF	50V
R710	1-249-435-11	CARBON 33K	5% 1/4W	C110	1-163-989-11	CERAMIC CHIP 0.033uF	10% 25V
R712	1-249-421-11	CARBON 2.2K	5% 1/4W	C111	1-163-038-00	CERAMIC CHIP 0.1uF	25V
R713	1-249-441-11	CARBON 100K	5% 1/4W	C112	1-163-038-00	CERAMIC CHIP 0.1uF	25V
R714	1-249-413-11	CARBON 470	5% 1/4W	C113	1-164-695-11	CERAMIC CHIP 0.0022uF	5% 50V
R715	1-249-413-11	CARBON 470	5% 1/4W	C114	1-164-005-11	CERAMIC CHIP 0.47uF	25V
R716	1-249-413-11	CARBON 470	5% 1/4W	C115	1-126-607-11	ELECT CHIP 47uF	20% 4V
R721	1-249-420-11	CARBON 1.8K	5% 1/4W	C116	1-163-016-00	CERAMIC CHIP 0.0039uF	10% 50V
R722	1-249-427-11	CARBON 6.8K	5% 1/4W	C117	1-164-005-11	CERAMIC CHIP 0.47uF	25V
R731	1-249-420-11	CARBON 1.8K	5% 1/4W	C118	1-107-823-11	CERAMIC CHIP 0.47uF	10% 16V
R732	1-249-427-11	CARBON 6.8K	5% 1/4W	C119	1-163-038-00	CERAMIC CHIP 0.1uF	25V
R752	1-249-433-11	CARBON 22K	5% 1/4W	C120	1-135-201-11	TANTALUM CHIP 10uF	20% 4V
R753	1-247-903-00	CARBON 1M	5% 1/4W	C121	1-163-038-00	CERAMIC CHIP 0.1uF	25V
R754	1-249-429-11	CARBON 10K	5% 1/4W	C122	1-164-232-11	CERAMIC CHIP 0.01uF	50V
R755	1-247-843-11	CARBON 3.3K	5% 1/4W	C123	1-163-038-00	CERAMIC CHIP 0.1uF	25V
R756	1-247-885-00	CARBON 180K	5% 1/4W	C124	1-126-607-11	ELECT CHIP 47uF	20% 4V
R757	1-249-425-11	CARBON 4.7K	5% 1/4W	C125	1-164-232-11	CERAMIC CHIP 0.01uF	50V
R758	1-249-421-11	CARBON 2.2K	5% 1/4W	C126	1-163-038-00	CERAMIC CHIP 0.1uF	25V
R759	1-247-895-00	CARBON 470K	5% 1/4W	C127	1-164-695-11	CERAMIC CHIP 0.0022uF	5% 50V
R760	1-247-887-00	CARBON 220K	5% 1/4W	C128	1-163-135-00	CERAMIC CHIP 560PF	5% 50V
R771	1-249-420-11	CARBON 1.8K	5% 1/4W	C129	1-163-038-00	CERAMIC CHIP 0.1uF	25V
R772	1-249-427-11	CARBON 6.8K	5% 1/4W	C130	1-164-336-11	CERAMIC CHIP 0.33uF	25V
R781	1-249-420-11	CARBON 1.8K	5% 1/4W	C131	1-163-038-00	CERAMIC CHIP 0.1uF	25V
R782	1-249-427-11	CARBON 6.8K	5% 1/4W	C132	1-163-037-11	CERAMIC CHIP 0.022uF	10% 25V
R1501	1-247-807-31	CARBON 100	5% 1/4W (AEP, UK, G, AED)	C133	1-163-145-00	CERAMIC CHIP 0.0015uF	5% 50V
R1502	1-249-432-11	CARBON 18K	5% 1/4W (AEP, UK, G, AED)	C134	1-164-346-11	CERAMIC CHIP 1uF	16V
R1503	1-249-426-11	CARBON 5.6K	5% 1/4W (AEP, UK, G, AED)	C135	1-163-251-11	CERAMIC CHIP 100PF	5% 50V
R1504	1-249-441-11	CARBON 100K	5% 1/4W (AEP, UK, G, AED)	C136	1-164-005-11	CERAMIC CHIP 0.47uF	25V
R1505	1-249-441-11	CARBON 100K	5% 1/4W (AEP, UK, G, AED)	C137	1-164-232-11	CERAMIC CHIP 0.01uF	50V
R1506	1-260-079-11	CARBON 22	5% 1/2W (AEP, UK, G, AED)	C139	1-163-235-11	CERAMIC CHIP 22PF	5% 50V
R1507	1-249-417-11	CARBON 1K	5% 1/4W (AEP, UK, G, AED)	C140	1-163-235-11	CERAMIC CHIP 22PF	5% 50V
R1508	1-249-429-11	CARBON 10K	5% 1/4W (AEP, UK, G, AED)	C141	1-163-038-00	CERAMIC CHIP 0.1uF	25V
				C142	1-163-038-00	CERAMIC CHIP 0.1uF	25V
				C145	1-135-201-11	TANTALUM CHIP 10uF	20% 4V
				C146	1-135-201-11	TANTALUM CHIP 10uF	20% 4V
				C147	1-163-275-11	CERAMIC CHIP 0.001uF	5% 50V
				C148	1-163-275-11	CERAMIC CHIP 0.001uF	5% 50V
				C149	1-164-346-11	CERAMIC CHIP 1uF	16V
				C153	1-135-259-11	TANTAL. CHIP 10uF	20% 6.3V

BD (CD)	BD (MD)
----------------	----------------

Ref. No.	Part No.	Description	Remark
C154	1-163-235-11	CERAMIC CHIP 22PF	5% 50V
		< CONNECTOR >	
CNU101	1-770-014-11	CONNECTOR, FFC/FPC 16P	
CNU102	1-770-013-11	CONNECTOR, FFC/FPC 19P	
		< IC >	
IC101	8-752-069-56	IC CXA1782BQ	
IC102	8-759-291-06	IC BA6397FP	
IC103	8-752-372-94	IC CXD2507AQ	
IC104	8-759-185-29	IC PCM1710U-B	
		< TRANSISTER >	
Q101	8-729-010-08	TRANSISTOR MSB710-R	
Q102	8-729-424-08	TRANSISTOR UN2111	
Q103	8-729-421-22	TRANSISTOR UN2211	
		< RESISTEER >	
R102	1-216-001-00	METAL CHIP 10	5% 1/10W
R103	1-216-049-11	METAL GLAZE 1K	5% 1/10W
R104	1-216-097-00	METAL GLAZE 100K	5% 1/10W
R105	1-216-093-00	METAL CHIP 68K	5% 1/10W
R106	1-216-093-00	METAL CHIP 68K	5% 1/10W
R107	1-216-093-00	METAL CHIP 68K	5% 1/10W
R108	1-216-093-00	METAL CHIP 68K	5% 1/10W
R109	1-216-097-00	METAL GLAZE 100K	5% 1/10W
R112	1-216-083-00	METAL CHIP 27K	5% 1/10W
R113	1-216-083-00	METAL CHIP 27K	5% 1/10W
R114	1-216-101-00	METAL CHIP 150K	5% 1/10W
R115	1-216-101-00	METAL CHIP 150K	5% 1/10W
R116	1-216-061-00	METAL CHIP 3.3K	5% 1/10W
R117	1-216-069-00	METAL CHIP 6.8K	5% 1/10W
R118	1-216-049-11	METAL GLAZE 1K	5% 1/10W
R119	1-216-089-00	METAL GLAZE 47K	5% 1/10W
R120	1-216-089-00	METAL GLAZE 47K	5% 1/10W
R121	1-216-114-00	METAL GLAZE 510K	5% 1/10W
R122	1-216-097-00	METAL GLAZE 100K	5% 1/10W
R123	1-216-099-00	METAL CHIP 120K	5% 1/10W
R124	1-216-091-00	METAL CHIP 56K	5% 1/10W
R125	1-216-069-00	METAL CHIP 6.8K	5% 1/10W
R126	1-216-063-00	METAL GLAZE 3.9K	5% 1/10W
R127	1-216-089-00	METAL GLAZE 47K	5% 1/10W
R128	1-216-105-00	METAL GLAZE 220K	5% 1/10W
R129	1-216-049-11	METAL GLAZE 1K	5% 1/10W
R130	1-216-079-00	METAL CHIP 18K	5% 1/10W
R131	1-216-079-00	METAL CHIP 18K	5% 1/10W
R132	1-216-061-00	METAL CHIP 3.3K	5% 1/10W
R133	1-216-061-00	METAL CHIP 3.3K	5% 1/10W
R134	1-216-065-00	METAL CHIP 4.7K	5% 1/10W
R135	1-216-065-00	METAL CHIP 4.7K	5% 1/10W
R136	1-216-073-00	METAL CHIP 10K	5% 1/10W
R137	1-216-065-00	METAL CHIP 4.7K	5% 1/10W
R138	1-216-049-11	METAL GLAZE 1K	5% 1/10W
R139	1-216-033-00	METAL CHIP 220	5% 1/10W
R140	1-216-081-00	METAL CHIP 22K	5% 1/10W
R141	1-216-061-00	METAL CHIP 3.3K	5% 1/10W
R142	1-216-061-00	METAL CHIP 3.3K	5% 1/10W
R143	1-216-121-00	METAL GLAZE 1M	5% 1/10W

Ref. No.	Part No.	Description	Remark
R144	1-216-073-00	METAL CHIP 10K	5% 1/10W
R145	1-216-097-00	METAL GLAZE 100K	5% 1/10W
R146	1-216-097-00	METAL GLAZE 100K	5% 1/10W
R147	1-216-049-11	METAL GLAZE 1K	5% 1/10W
R148	1-216-049-11	METAL GLAZE 1K	5% 1/10W
R149	1-216-049-11	METAL GLAZE 1K	5% 1/10W
R150	1-216-037-00	METAL CHIP 330	5% 1/10W
R151	1-216-037-00	METAL CHIP 330	5% 1/10W
R152	1-216-037-00	METAL CHIP 330	5% 1/10W
R153	1-216-082-00	METAL GLAZE 24K	5% 1/10W
R154	1-216-065-00	METAL CHIP 4.7K	5% 1/10W
R156	1-216-085-00	METAL CHIP 33K	5% 1/10W
R157	1-216-069-00	METAL CHIP 6.8K	5% 1/10W
R158	1-216-001-00	METAL CHIP 10	5% 1/10W
		< VARIABLE RESISTER >	
RV101	1-223-587-11	RES, ADJ, CARBON 22K	
RV102	1-223-587-11	RES, ADJ, CARBON 22K	
RV103	1-223-587-11	RES, ADJ, CARBON 22K	
		< SWITCH >	
S101	1-572-085-11	SWITCH, LEAF (LIMIT)	
		< VIBRATOR >	
X101	1-579-280-11	VIBRATOR, CRYSTAL (16.9344MHz)	

*	A-4699-808-A	BD (MD) BOARD, COMPLETE	

		< CAPACITOR >	
C101	1-104-851-11	TANTAL. CHIP 10uF	20% 10V
C102	1-163-038-00	CERAMIC CHIP 0.1uF	25V
C103	1-104-851-11	TANTAL. CHIP 10uF	20% 10V
C104	1-104-851-11	TANTAL. CHIP 10uF	20% 10V
C105	1-164-232-11	CERAMIC CHIP 0.01uF	50V
C106	1-163-275-11	CERAMIC CHIP 0.001uF	5% 50V
C107	1-163-038-00	CERAMIC CHIP 0.1uF	25V
C108	1-163-038-00	CERAMIC CHIP 0.1uF	25V
C109	1-163-037-11	CERAMIC CHIP 0.022uF	10% 25V
C110	1-163-038-00	CERAMIC CHIP 0.1uF	25V
C111	1-164-344-11	CERAMIC CHIP 0.068uF	10% 25V
C112	1-163-017-00	CERAMIC CHIP 0.0047uF	5% 50V
C113	1-164-346-11	CERAMIC CHIP 1uF	16V
C115	1-164-489-11	CERAMIC CHIP 0.22uF	10% 16V
C116	1-163-037-11	CERAMIC CHIP 0.022uF	10% 25V
C117	1-163-038-00	CERAMIC CHIP 0.1uF	25V
C118	1-163-038-00	CERAMIC CHIP 0.1uF	25V
C119	1-104-851-11	TANTAL. CHIP 10uF	20% 10V
C121	1-126-206-11	ELECT CHIP 100uF	20% 6.3V
C122	1-164-232-11	CERAMIC CHIP 0.01uF	50V
C123	1-163-038-00	CERAMIC CHIP 0.1uF	25V
C124	1-163-038-00	CERAMIC CHIP 0.1uF	25V
C127	1-163-038-00	CERAMIC CHIP 0.1uF	25V
C128	1-164-232-11	CERAMIC CHIP 0.01uF	50V
C129	1-107-823-11	CERAMIC CHIP 0.47uF	10% 16V
C130	1-163-251-11	CERAMIC CHIP 100PF	5% 50V
C131	1-163-023-00	CERAMIC CHIP 0.015uF	5% 50V

Ref. No.	Part No.	Description			Remark	Ref. No.	Part No.	Description			Remark
C132	1-107-823-11	CERAMIC CHIP	0.47uF	10%	16V	C363	1-163-251-11	CERAMIC CHIP	100PF	5%	50V
C133	1-163-017-00	CERAMIC CHIP	0.0047uF	5%	50V	C401	1-163-038-00	CERAMIC CHIP	0.1uF		25V
C134	1-163-038-00	CERAMIC CHIP	0.1uF		25V	C402	1-164-232-11	CERAMIC CHIP	0.01uF	10%	50V
C135	1-163-038-00	CERAMIC CHIP	0.1uF		25V	C2001	1-163-038-00	CERAMIC CHIP	0.1uF		25V
C136	1-126-206-11	ELECT CHIP	100uF	20%	6.3V	C2002	1-163-038-00	CERAMIC CHIP	0.1uF		25V
C139	1-163-235-11	CERAMIC CHIP	22PF	5%	50V	C2003	1-163-038-00	CERAMIC CHIP	0.1uF		25V
C140	1-163-099-00	CERAMIC CHIP	18PF	5%	50V	C2004	1-163-038-00	CERAMIC CHIP	0.1uF		25V
C142	1-163-251-11	CERAMIC CHIP	100PF	5%	50V	< CONNECTOR >					
C143	1-163-251-11	CERAMIC CHIP	100PF	5%	50V	CN101	1-766-508-11	CONNECTOR, FFC/FPC (ZIF) 22P			
C144	1-163-251-11	CERAMIC CHIP	100PF	5%	50V	CN104	1-778-283-11	CONNECTOR, FFC/FPC 4P			
C151	1-126-206-11	ELECT CHIP	100uF	20%	6.3V	CN106	1-774-771-11	CONNECTOR, FFC/FPC 14P			
C152	1-163-038-00	CERAMIC CHIP	0.1uF		25V	CN107	1-779-854-11	CONNECTOR, FFC/FPC 25P			
C153	1-164-232-11	CERAMIC CHIP	0.01uF		50V	< DIODE >					
C156	1-163-038-00	CERAMIC CHIP	0.1uF		25V	D101	8-719-988-62	DIODE 1SS355			
C158	1-163-019-00	CERAMIC CHIP	0.0068uF	10%	50V	D181	8-719-046-86	DIODE F1J6TP			
C160	1-104-601-11	ELECT CHIP	10uF	20%	10V	D183	8-719-046-86	DIODE F1J6TP			
C161	1-104-601-11	ELECT CHIP	10uF	20%	10V	< IC >					
C163	1-164-232-11	CERAMIC CHIP	0.01uF		50V	IC101	8-752-080-95	IC CXA2523AR			
C164	1-164-232-11	CERAMIC CHIP	0.01uF		50V	IC103	8-729-903-10	IC TRANSISTOR FMW1			
C167	1-163-038-00	CERAMIC CHIP	0.1uF		25V	IC121	8-752-384-47	IC CXD2652AR			
C168	1-163-038-00	CERAMIC CHIP	0.1uF		25V	IC124	8-759-334-38	IC MSM51V4400-70TS-K			
C169	1-104-851-11	TANTAL. CHIP	10uF	20%	10V	IC152	8-759-430-25	IC BH6511FS-E2			
C171	1-163-038-00	CERAMIC CHIP	0.1uF		25V	IC153	8-759-481-19	IC LB1830M-S-TE-L			
C181	1-126-206-11	ELECT CHIP	100uF	20%	6.3V	IC171	8-759-428-58	IC XL24C01AF-E2			
C182	1-163-038-00	CERAMIC CHIP	0.1uF		25V	IC181	8-759-481-17	IC MC74ACT08DTR2			
C183	1-163-038-00	CERAMIC CHIP	0.1uF		25V	IC192	8-759-460-72	IC BA033FP			
C184	1-117-970-11	ELECT CHIP	22uF	20%	10V	IC201	8-759-471-38	IC AK4520A-VF-E2			
C185	1-164-611-11	CERAMIC CHIP	0.001uF	10%	500V	IC316	8-759-525-28	IC M30610MC-116FP			
C188	1-164-232-11	CERAMIC CHIP	0.01uF		50V	IC401	8-759-242-70	IC TC7WU04F			
C189	1-163-989-11	CERAMIC CHIP	0.033uF	10%	25V	< COIL/RESISTOR >					
C190	1-126-206-11	ELECT CHIP	100uF	20%	6.3V	L101	1-414-235-11	INDUCTOR, FERRITE BEAD			
C191	1-163-038-00	CERAMIC CHIP	0.1uF		25V	L102	1-414-235-11	INDUCTOR, FERRITE BEAD			
C192	1-163-038-00	CERAMIC CHIP	0.1uF		25V	L103	1-414-235-11	INDUCTOR, FERRITE BEAD			
C197	1-163-038-00	CERAMIC CHIP	0.1uF		25V	L105	1-414-235-11	INDUCTOR, FERRITE BEAD			
C201	1-164-695-11	CERAMIC CHIP	0.0022uF	5%	50V	L106	1-414-235-11	INDUCTOR, FERRITE BEAD			
C202	1-164-695-11	CERAMIC CHIP	0.0022uF	5%	50V	L121	1-414-235-11	INDUCTOR, FERRITE BEAD			
C203	1-163-038-00	CERAMIC CHIP	0.1uF		25V	L122	1-414-235-11	INDUCTOR, FERRITE BEAD			
C205	1-126-206-11	ELECT CHIP	100uF	20%	6.3V	L151	1-412-622-51	INDUCTOR 10uH			
C206	1-115-363-11	CERAMIC CHIP	10uF		10V	L152	1-412-622-51	INDUCTOR 10uH			
C207	1-163-038-00	CERAMIC CHIP	0.1uF		25V	L153	1-412-039-51	INDUCTOR CHIP 100uH			
C208	1-115-363-11	CERAMIC CHIP	10uF		10V	L154	1-412-039-51	INDUCTOR CHIP 100uH			
C209	1-163-038-00	CERAMIC CHIP	0.1uF		25V	L161	1-414-235-11	INDUCTOR, FERRITE BEAD			
C210	1-163-038-00	CERAMIC CHIP	0.1uF		25V	L162	1-414-235-11	INDUCTOR, FERRITE BEAD			
C212	1-163-038-00	CERAMIC CHIP	0.1uF		25V	L181	1-424-675-11	COIL, CHOKE 33uH			
C213	1-115-363-11	CERAMIC CHIP	10uF		10V	L201	1-412-776-11	INDUCTOR 1uH			
C214	1-115-363-11	CERAMIC CHIP	10uF		10V	L301	1-414-235-11	INDUCTOR, FERRITE BEAD			
C216	1-124-779-00	ELECT CHIP	10uF	20%	16V	L351	1-216-295-11	CONDUCTOR, CHIP (2012)			
C350	1-163-038-00	CERAMIC CHIP	0.1uF		25V	L401	1-216-025-00	METAL GLAZE 100 5% 1/10W			
C352	1-124-779-00	ELECT CHIP	10uF	20%	16V	L1001	1-500-445-21	INDUCTOR, FERRITE BEAD			
C353	1-163-038-00	CERAMIC CHIP	0.1uF		25V	< TRANSISTOR >					
C354	1-163-038-00	CERAMIC CHIP	0.1uF		25V	Q101	8-729-028-91	TRANSISTOR DTA144EUA-T106			
C355	1-163-251-11	CERAMIC CHIP	100PF	5%	50V	Q102	8-729-026-53	TRANSISTOR 2SA1576A-T106-QR			
C357	1-164-232-11	CERAMIC CHIP	0.01uF		50V	Q103	8-729-028-99	TRANSISTOR RT1N144M-TP-1			
C358	1-163-251-11	CERAMIC CHIP	100PF	5%	50V						
C359	1-163-251-11	CERAMIC CHIP	100PF	5%	50V						
C361	1-163-038-00	CERAMIC CHIP	0.1uF		25V						
C362	1-163-251-11	CERAMIC CHIP	100PF	5%	50V						

BD (MD)

Ref. No.	Part No.	Description	Remark			Ref. No.	Part No.	Description	Remark		
Q104	8-729-028-99	TRANSISTOR RT1N144M-TP-1				R189	1-216-073-00	METAL CHIP 10K	5%	1/10W	
Q162	8-729-101-07	TRANSISTOR 2SB798-DL				R190	1-216-073-00	METAL CHIP 10K	5%	1/10W	
Q163	8-729-028-91	TRANSISTOR DTA144EUA-T106				R195	1-216-295-11	CONDUCTOR, CHIP (2012)			
Q181	8-729-018-75	TRANSISTOR 2SJ278MY				R196	1-216-295-11	CONDUCTOR, CHIP (2012)			
Q182	8-729-017-65	TRANSISTOR 2SK1764KY				R198	1-216-295-11	CONDUCTOR, CHIP (2012)			
Q350	8-729-028-99	TRANSISTOR RT1N144M-TP-1				R199	1-216-295-11	CONDUCTOR, CHIP (2012)			
		< RESISTOR >				R200	1-216-295-11	CONDUCTOR, CHIP (2012)			
R101	1-216-025-00	METAL GLAZE 100	5%	1/10W		R202	1-216-041-00	METAL CHIP 470	5%	1/10W	
R103	1-216-049-11	METAL GLAZE 1K	5%	1/10W		R203	1-216-025-00	METAL GLAZE 100	5%	1/10W	
R104	1-216-073-00	METAL CHIP 10K	5%	1/10W		R204	1-216-025-00	METAL GLAZE 100	5%	1/10W	
R105	1-216-065-00	METAL CHIP 4.7K	5%	1/10W		R210	1-216-041-00	METAL CHIP 470	5%	1/10W	
R106	1-216-133-00	METAL CHIP 3.3M	5%	1/10W		R330	1-216-073-00	METAL CHIP 10K	5%	1/10W	
R107	1-216-113-00	METAL CHIP 470K	5%	1/10W		R331	1-216-073-00	METAL CHIP 10K	5%	1/10W	
R110	1-216-073-00	METAL CHIP 10K	5%	1/10W		R332	1-216-097-00	METAL GLAZE 100K	5%	1/10W	
R112	1-216-089-00	METAL GLAZE 47K	5%	1/10W		R333	1-216-073-00	METAL CHIP 10K	5%	1/10W	
R113	1-216-049-11	METAL GLAZE 1K	5%	1/10W		R351	1-216-053-00	METAL CHIP 1.5K	5%	1/10W	
R115	1-216-049-11	METAL GLAZE 1K	5%	1/10W		R352	1-216-061-00	METAL GLAZE 3.3K	5%	1/10W	
R117	1-216-113-00	METAL CHIP 470K	5%	1/10W		R356	1-216-025-00	METAL GLAZE 100	5%	1/10W	
R121	1-216-097-00	METAL GLAZE 100K	5%	1/10W		R361	1-216-073-00	METAL CHIP 10K	5%	1/10W	
R125	1-216-025-00	METAL GLAZE 100	5%	1/10W		R362	1-216-025-00	METAL GLAZE 100	5%	1/10W	
R128	1-216-041-00	METAL GLAZE 470	5%	1/10W		R363	1-216-073-00	METAL CHIP 10K	5%	1/10W	
R131	1-216-073-00	METAL CHIP 10K	5%	1/10W		R366	1-216-097-00	METAL GLAZE 100K	5%	1/10W	
R132	1-216-097-00	METAL GLAZE 100K	5%	1/10W		R367	1-216-097-00	METAL GLAZE 100K	5%	1/10W	
R133	1-216-117-00	METAL CHIP 680K	5%	1/10W		R379	1-216-073-00	METAL CHIP 10K	5%	1/10W	
R134	1-216-049-11	METAL GLAZE 1K	5%	1/10W		R380	1-216-073-00	METAL CHIP 10K	5%	1/10W	
R135	1-216-061-00	METAL CHIP 3.3K	5%	1/10W		R381	1-216-073-00	METAL CHIP 10K	5%	1/10W	
R136	1-216-049-11	METAL GLAZE 1K	5%	1/10W		R382	1-216-073-00	METAL CHIP 10K	5%	1/10W	
R137	1-216-025-00	METAL GLAZE 100	5%	1/10W		R383	1-216-073-00	METAL CHIP 10K	5%	1/10W	
R140	1-216-029-00	METAL CHIP 150	5%	1/10W		R384	1-216-073-00	METAL CHIP 10K	5%	1/10W	
R142	1-216-073-00	METAL CHIP 10K	5%	1/10W		R386	1-216-073-00	METAL CHIP 10K	5%	1/10W	
R143	1-216-073-00	METAL CHIP 10K	5%	1/10W		R387	1-216-069-00	METAL GLAZE 6.8K	5%	1/10W	
R144	1-216-025-00	METAL GLAZE 100	5%	1/10W		R388	1-216-069-00	METAL GLAZE 6.8K	5%	1/10W	
R146	1-216-037-00	METAL CHIP 330	5%	1/10W		R389	1-216-069-00	METAL GLAZE 6.8K	5%	1/10W	
R147	1-216-025-00	METAL GLAZE 100	5%	1/10W		R391	1-216-073-00	METAL CHIP 10K	5%	1/10W	
R148	1-216-045-00	METAL CHIP 680	5%	1/10W		R393	1-216-073-00	METAL CHIP 10K	5%	1/10W	
R158	1-216-097-00	METAL GLAZE 100K	5%	1/10W		R400	1-216-073-00	METAL CHIP 10K	5%	1/10W	
R159	1-216-097-00	METAL GLAZE 100K	5%	1/10W		R401	1-216-089-00	METAL GLAZE 47K	5%	1/10W	
R161	1-216-057-00	METAL CHIP 2.2K	5%	1/10W		R402	1-216-113-00	METAL GLAZE 470K	5%	1/10W	
R162	1-216-057-00	METAL CHIP 2.2K	5%	1/10W		R405	1-216-063-00	METAL GLAZE 3.9K	5%	1/10W	
R163	1-216-057-00	METAL CHIP 2.2K	5%	1/10W		R420	1-216-097-00	METAL GLAZE 100K	5%	1/10W	
R164	1-216-033-00	METAL CHIP 220	5%	1/10W		R421	1-216-097-00	METAL GLAZE 100K	5%	1/10W	
R165	1-216-097-00	METAL GLAZE 100K	5%	1/10W		R422	1-216-097-00	METAL GLAZE 100K	5%	1/10W	
R166	1-220-149-11	METAL GLAZE 2.2	10%	1/2W		R423	1-216-097-00	METAL GLAZE 100K	5%	1/10W	
R167	1-216-065-00	METAL CHIP 4.7K	5%	1/10W		R424	1-216-097-00	METAL GLAZE 100K	5%	1/10W	
R169	1-219-724-11	METAL CHIP 1	1%	1/4W		R425	1-216-097-00	METAL GLAZE 100K	5%	1/10W	
R170	1-216-073-00	METAL CHIP 10K	5%	1/10W		R429	1-216-097-00	METAL GLAZE 100K	5%	1/10W	
R171	1-216-073-00	METAL CHIP 10K	5%	1/10W		R430	1-216-097-00	METAL GLAZE 100K	5%	1/10W	
R175	1-216-061-00	METAL CHIP 3.3K	5%	1/10W		R431	1-216-097-00	METAL GLAZE 100K	5%	1/10W	
R177	1-216-061-00	METAL CHIP 3.3K	5%	1/10W		R432	1-216-097-00	METAL GLAZE 100K	5%	1/10W	
R178	1-216-295-11	CONDUCTOR, CHIP (2012)				R433	1-216-097-00	METAL GLAZE 100K	5%	1/10W	
R179	1-216-091-00	METAL CHIP 56K	5%	1/10W		R434	1-216-097-00	METAL GLAZE 100K	5%	1/10W	
R180	1-216-073-00	METAL CHIP 10K	5%	1/10W		R435	1-216-097-00	METAL GLAZE 100K	5%	1/10W	
R182	1-216-089-00	METAL GLAZE 47K	5%	1/10W		R438	1-216-097-00	METAL GLAZE 100K	5%	1/10W	
R183	1-216-089-00	METAL GLAZE 47K	5%	1/10W		R439	1-216-097-00	METAL GLAZE 100K	5%	1/10W	
R184	1-216-073-00	METAL CHIP 10K	5%	1/10W		R440	1-216-097-00	METAL GLAZE 100K	5%	1/10W	
R188	1-216-073-00	METAL CHIP 10K	5%	1/10W		R441	1-216-097-00	METAL GLAZE 100K	5%	1/10W	
						R442	1-216-097-00	METAL GLAZE 100K	5%	1/10W	
						R443	1-216-097-00	METAL GLAZE 100K	5%	1/10W	

Ref. No.	Part No.	Description	Quantity	Tolerance	Power	Remark	Ref. No.	Part No.	Description	Quantity	Tolerance	Power	Remark
R444	1-216-097-00	METAL GLAZE	100K	5%	1/10W				< CONNECTOR >				
R445	1-216-097-00	METAL GLAZE	100K	5%	1/10W		* CN401	1-568-858-11	SOCKET, CONNECTOR 15P				
R448	1-216-097-00	METAL GLAZE	100K	5%	1/10W		CN402	1-564-506-11	PLUG, CONNECTOR 3P				
R449	1-216-097-00	METAL GLAZE	100K	5%	1/10W		* CN404	1-770-379-11	CONNECTOR, BOARD TO BOARD 6P				
R451	1-216-097-00	METAL GLAZE	100K	5%	1/10W		* CN420	1-565-561-11	PIN, CONNECTOR 3P (AU BUS)				
R454	1-216-097-00	METAL GLAZE	100K	5%	1/10W		* CN430	1-565-500-11	CONNECTOR, BOARD TO BOARD 9P				
R455	1-216-097-00	METAL GLAZE	100K	5%	1/10W		* CN490	1-568-943-11	PIN, CONNECTOR 5P				
R456	1-216-097-00	METAL GLAZE	100K	5%	1/10W				< DIODE >				
R457	1-216-097-00	METAL GLAZE	100K	5%	1/10W		D422	8-719-911-19	DIODE 1SS119				
R458	1-216-097-00	METAL GLAZE	100K	5%	1/10W		D430	8-719-911-19	DIODE 1SS119				
R460	1-216-073-00	METAL CHIP	10K	5%	1/10W		D447	8-719-911-19	DIODE 1SS119				
R462	1-216-073-00	METAL CHIP	10K	5%	1/10W		D497	8-719-911-19	DIODE 1SS119				
R502	1-216-295-11	CONDUCTOR, CHIP (2012)							< JACK >				
R504	1-216-295-11	CONDUCTOR, CHIP (2012)											
R600	1-216-053-00	METAL GLAZE	1.5K	5%	1/10W		J401	1-764-767-21	JACK, PIN 2P (TAPE B INPUT)				
R602	1-216-025-00	METAL GLAZE	100	5%	1/10W		J402	1-764-767-21	JACK, PIN 2P (TAPE A OUTPUT)				
R603	1-216-025-00	METAL GLAZE	100	5%	1/10W				< COIL >				
R604	1-216-061-00	METAL CHIP	3.3K	5%	1/10W		L448	1-420-872-00	COIL, AIR-CORE				
R605	1-216-025-00	METAL GLAZE	100	5%	1/10W		L498	1-420-872-00	COIL, AIR-CORE				
R606	1-216-061-00	METAL CHIP	3.3K	5%	1/10W				< TRANSISTOR >				
R607	1-216-061-00	METAL CHIP	3.3K	5%	1/10W		Q400	8-729-620-05	TRANSISTOR 2SC2603-EF				
R608	1-216-025-00	METAL GLAZE	100	5%	1/10W		Q410	8-729-141-30	TRANSISTOR 2SC3623A-LK				
R2001	1-216-001-00	METAL CHIP	10	5%	1/10W		Q420	8-729-620-05	TRANSISTOR 2SC2603-EF				
R2002	1-216-296-00	CONDUCTOR, CHIP (3216)					Q431	8-729-900-80	TRANSISTOR DTC114ES				
							Q432	8-729-620-05	TRANSISTOR 2SC2603-EF				
		< VIBRATOR >					Q433	8-729-620-05	TRANSISTOR 2SC2603-EF				
X101	1-767-151-11	VIBRATOR, CRYSTAL (22MHZ)					Q434	8-729-119-76	TRANSISTOR 2SA1175-HFE				
X302	1-767-670-11	VIBRATOR, CERAMIC (7MHZ)					Q435	8-729-620-05	TRANSISTOR 2SC2603-EF				
							Q436	8-729-620-05	TRANSISTOR 2SC2603-EF				
							Q450	8-729-620-05	TRANSISTOR 2SC2603-EF				
							Q460	8-729-141-30	TRANSISTOR 2SC3623A-LK				
									< RESISTOR >				
							R401	1-249-417-11	CARBON 1K 5%	1/4W			
							R402	1-249-441-11	CARBON 100K 5%	1/4W			
							R403	1-249-425-11	CARBON 4.7K 5%	1/4W			
							R404	1-249-425-11	CARBON 4.7K 5%	1/4W			
							R405	1-249-429-11	CARBON 10K 5%	1/4W			
							R411	1-249-441-11	CARBON 100K 5%	1/4W			
							R412	1-249-417-11	CARBON 1K 5%	1/4W			
							R413	1-249-429-11	CARBON 10K 5%	1/4W			
							R414	1-249-421-11	CARBON 2.2K 5%	1/4W			
							R415	1-249-441-11	CARBON 100K 5%	1/4W			
							R421	1-249-393-11	CARBON 10 5%	1/4W			
							R422	1-249-429-11	CARBON 10K 5%	1/4W			
							R423	1-249-425-11	CARBON 4.7K 5%	1/4W			
							R431	1-249-437-11	CARBON 47K 5%	1/4W			
							R433	1-249-433-11	CARBON 22K 5%	1/4W			
							R434	1-249-431-11	CARBON 15K 5%	1/4W			
							R435	1-249-437-11	CARBON 47K 5%	1/4W			
							R436	1-249-433-11	CARBON 22K 5%	1/4W			
							R437	1-249-417-11	CARBON 1K 5%	1/4W			
							△R444	1-216-478-11	METAL OXIDE 390 5%	3W F (AEP, UK, G, AED)			

The components identified by mark △ or dotted line with mark △ are critical for safety. Replace only with part number specified.	Les composants identifiés par une marque △ sont critiques pour la sécurité. Ne les remplacer que par une pièce portant le numéro spécifié.
--	--

JACK	LOADING	MAIN
-------------	----------------	-------------

Ref. No.	Part No.	Description	Remark	Ref. No.	Part No.	Description	Remark
△R444	1-215-914-11	METAL OXIDE	330 5% 3W F (CND, MY, SP, HK)	C522	1-126-934-11	ELECT	220uF 20% 16V
R445	1-260-089-11	CARBON	150 5% 1/2W	C523	1-126-934-11	ELECT	220uF 20% 16V
R446	1-260-089-11	CARBON	150 5% 1/2W	C525	1-126-933-11	ELECT	100uF 20% 16V
R447	1-249-431-11	CARBON	15K 5% 1/4W	C531	1-126-969-11	ELECT	220uF 20% 50V
R448	1-260-076-11	CARBON	10 5% 1/2W	C532	1-126-969-11	ELECT	220uF 20% 50V
R449	1-260-076-11	CARBON	10 5% 1/2W (AEP, UK, G, AED)	C533	1-126-969-11	ELECT	220uF 20% 50V
R451	1-249-417-11	CARBON	1K 5% 1/4W	C535	1-126-964-11	ELECT	10uF 20% 50V
R452	1-249-441-11	CARBON	100K 5% 1/4W	C536	1-126-947-11	ELECT	47uF 20% 35V
R453	1-249-425-11	CARBON	4.7K 5% 1/4W	C550	1-117-850-11	ELECT (SOLID)	15000uF 20% 16V
R454	1-249-425-11	CARBON	4.7K 5% 1/4W	C551	1-136-165-00	FILM	0.1uF 5% 50V
R455	1-249-429-11	CARBON	10K 5% 1/4W	C552	1-136-165-00	FILM	0.1uF 5% 50V
R461	1-249-441-11	CARBON	100K 5% 1/4W	C561	1-126-791-11	ELECT	10uF 20% 16V
R462	1-249-417-11	CARBON	1K 5% 1/4W	C562	1-126-916-11	ELECT	1000uF 20% 6.3V
R463	1-249-429-11	CARBON	10K 5% 1/4W	C563	1-162-306-11	CERAMIC	0.01uF 20% 16V
R464	1-249-421-11	CARBON	2.2K 5% 1/4W	C564	1-126-964-11	ELECT	10uF 20% 50V
R465	1-249-441-11	CARBON	100K 5% 1/4W	C565	1-126-916-11	ELECT	1000uF 20% 6.3V
R495	1-260-089-11	CARBON	150 5% 1/2W	C566	1-126-916-11	ELECT	1000uF 20% 6.3V
R496	1-260-089-11	CARBON	150 5% 1/2W	C572	1-126-960-11	ELECT	1uF 20% 50V
R497	1-249-431-11	CARBON	15K 5% 1/4W	C573	1-126-965-11	ELECT	22uF 20% 50V
R498	1-260-076-11	CARBON	10 5% 1/2W	C574	1-126-923-11	ELECT	220uF 20% 10V
R499	1-260-076-11	CARBON	10 5% 1/2W (AEP, UK, G, AED)	C575	1-126-923-11	ELECT	220uF 20% 10V
		< RELAY >		C576	1-126-964-11	ELECT	10uF 20% 50V
RY430	1-515-833-11	RELAY		C577	1-126-923-11	ELECT	220uF 20% 10V
		< TERMINAL >		C578	1-164-159-11	CERAMIC	0.1uF 50V
TM440	1-537-238-31	TERMINAL BOARD (SPEAKER)		C579	1-110-489-11	CAPACITOR	1F 5.5V
*****				C580	1-126-933-11	ELECT	100uF 20% 16V
*	1-634-461-11	LOADING BOARD	*****	C591	1-126-163-11	ELECT	4.7uF 20% 50V
		< CONNECTOR >		C592	1-164-159-11	CERAMIC	0.1uF 50V
* CN291	1-564-498-11	PIN, CONNECTOR 5P		C602	1-164-159-11	CERAMIC	0.1uF 50V
		< SWITCH >		C604	1-126-960-11	ELECT	1uF 20% 50V
S291	1-571-924-11	SWITCH, LEAF (LOAD OUT)		C608	1-126-096-11	ELECT	10uF 20% 25V
S292	1-571-924-11	SWITCH, LEAF (LOAD IN)		C612	1-124-589-11	ELECT	47uF 20% 16V
*****				C613	1-162-306-11	CERAMIC	0.01uF 20% 16V
*	A-4403-408-A	MAIN BOARD, COMPLETE (AEP, UK, G, AED)		C614	1-102-514-11	CERAMIC	22PF 5% 50V
*	A-4403-415-A	MAIN BOARD, COMPLETE (MY, SP, HK)		C615	1-102-514-11	CERAMIC	22PF 5% 50V
*	A-4407-383-A	MAIN BOARD, COMPLETE (CND)	*****	C616	1-124-589-11	ELECT	47uF 20% 16V
		< CAPACITOR >		C617	1-162-294-31	CERAMIC	0.001uF 10% 50V
C501	1-128-548-11	ELECT	4700uF 20% 25V	C618	1-136-165-00	FILM	0.1uF 5% 50V
C502	1-104-665-11	ELECT	100uF 20% 25V	C619	1-136-165-00	FILM	0.1uF 5% 50V
C503	1-136-165-00	FILM	0.1uF 5% 50V	C620	1-136-165-00	FILM	0.1uF 5% 50V
C504	1-136-165-00	FILM	0.1uF 5% 50V	C621	1-124-589-11	ELECT	47uF 20% 16V
C511	1-126-096-11	ELECT	10uF 20% 35V	C622	1-125-623-11	CAP, DOUBLE LAYER	0.22F 5.5V
C512	1-126-926-11	ELECT	1000uF 20% 10V	C807	1-164-159-11	CERAMIC	0.1uF 50V
C513	1-162-306-11	CERAMIC	0.01uF 20% 16V	C808	1-126-967-11	ELECT	47uF 20% 16V
C514	1-126-926-11	ELECT	1000uF 20% 10V	C809	1-126-925-11	ELECT	470uF 20% 10V
C515	1-126-934-11	ELECT	220uF 20% 16V	C814	1-162-306-11	CERAMIC	0.01uF 20% 16V
C516	1-126-933-11	ELECT	100uF 20% 16V	C815	1-162-306-11	CERAMIC	0.01uF 20% 16V
				C816	1-162-306-11	CERAMIC	0.01uF 20% 16V
				C817	1-126-967-11	ELECT	47uF 20% 16V
				C821	1-126-096-11	ELECT	10uF 20% 35V
				C822	1-162-290-31	CERAMIC	470PF 10% 50V
				C823	1-126-916-11	ELECT	1000uF 20% 6.3V
				C831	1-126-096-11	ELECT	10uF 20% 35V
				C832	1-162-290-31	CERAMIC	470PF 10% 50V
				C833	1-126-964-11	ELECT	10uF 20% 50V
				C834	1-162-306-11	CERAMIC	0.01uF 30% 16V
				C835	1-162-285-31	CERAMIC	180PF 10% 50V
				C837	1-126-925-11	CERAMIC	470uF 20% 10V

<p>The components identified by mark △ or dotted line with mark △ are critical for safety. Replace only with part number specified.</p>	<p>Les composants identifiés par une marque △ sont critiques pour la sécurité. Ne les remplacer que par une pièce portant le numéro spécifié.</p>
---	---

Ref. No.	Part No.	Description	Remark	Ref. No.	Part No.	Description	Remark
C839	1-162-282-31	CERAMIC	100PF 10%			< GROUND TERMINAL >	
C841	1-164-159-11	CERAMIC	0.1uF				
C842	1-164-159-11	CERAMIC	0.1uF				
C871	1-126-163-11	ELECT	4.7uF 20%			< FERRITE BEAD >	
C872	1-126-163-11	ELECT	4.7uF 20%				
C881	1-126-959-11	ELECT	0.47uF 20%				
						< CONNECTOR >	
CN503	1-564-511-11	PLUG, CONNECTOR	8P				
CN506	1-770-412-11	CONNECTOR, BOARD TO BOARD	6P				
CN590	1-564-506-11	PLUG, CONNECTOR	3P				
CN801	1-770-067-11	CONNECTOR, FFC/FPC	19P				
* CN802	1-564-339-00	PIN, CONNECTOR	5P				
CN820	1-770-653-11	CONNECTOR, FFC/FPC	25P				
CN850	1-691-648-11	SOCKET, CONNECTOR	15P				
CN870	1-568-834-11	SOCKET, CONNECTOR	15P				
CN871	1-779-820-11	CONNECTOR, BOARD TO BOARD	14P				
CN872	1-779-820-11	CONNECTOR, BOARD TO BOARD	14P				
* CN873	1-568-839-11	SOCKET, CONNECTOR	23P				
						< DIODE >	
D501	8-719-200-82	DIODE	11ES2				
D502	8-719-200-82	DIODE	11ES2				
D503	8-719-200-82	DIODE	11ES2				
D504	8-719-200-82	DIODE	11ES2				
D511	8-719-013-13	DIODE	UZ-8.2BSC-TP				
D521	8-719-013-16	DIODE	UZ-9.1BSB-TP				
D531	8-719-200-82	DIODE	11ES2				
D532	8-719-200-82	DIODE	11ES2				
D533	8-719-200-82	DIODE	11ES2				
D534	8-719-011-18	DIODE	UZ-33BSC-TP				
D551	8-719-200-02	DIODE	10E2				
D552	8-719-200-02	DIODE	10E2				
D553	8-719-200-02	DIODE	10E2				
D554	8-719-200-02	DIODE	10E2				
D561	8-719-200-82	DIODE	11ES2				
D562	8-719-911-19	DIODE	1SS119				
D563	8-719-200-82	DIODE	11ES2				
D571	8-719-911-19	DIODE	1SS119				
D572	8-719-911-19	DIODE	1SS119				
D581	8-719-911-19	DIODE	1SS119				
D582	8-719-911-19	DIODE	1SS119				
D591	8-719-110-22	DIODE	RD11ES-B2				
D601	8-719-911-19	DIODE	1SS119				
D602	8-719-911-19	DIODE	1SS119				
D603	8-719-200-82	DIODE	11ES2				
D604	8-719-200-82	DIODE	11ES2				
D605	8-719-911-19	DIODE	1SS119				
D801	8-719-911-19	DIODE	1SS119				
D802	8-719-911-19	DIODE	1SS119				
D803	8-719-010-33	DIODE	UZ-4.7BSB				
D881	8-719-911-19	DIODE	1SS119				
D882	8-719-911-19	DIODE	1SS119				
						< COIL >	
L523	1-408-117-00	INDUCTOR	10uH				
L601	1-410-509-11	INDUCTOR	10uH				
L739	1-410-470-11	INDUCTOR	10uH				
						< TRANSISTOR >	
Q510	8-729-111-29	TRANSISTOR	2SD1616A-K				
Q520	8-729-118-00	TRANSISTOR	2SB1116-L				
Q521	8-729-119-76	TRANSISTOR	2SA1175-HFE				
Q530	8-729-018-59	TRANSISTOR	2SB1375-LC				
Q561	8-729-118-01	TRANSISTOR	2SB1116				
Q562	8-729-422-73	TRANSISTOR	UN4212				
Q571	8-729-422-57	TRANSISTOR	UN4111				
Q572	8-729-900-80	TRANSISTOR	DTC114ES				
Q591	8-729-119-76	TRANSISTOR	2SA1175-HFE				
Q592	8-729-021-82	TRANSISTOR	2SD2396K				
Q601	8-729-900-80	TRANSISTOR	DTC114ES				
Q602	8-729-620-05	TRANSISTOR	2SC2603-EF				
Q871	8-729-422-57	TRANSISTOR	UN4111				
Q872	8-729-422-57	TRANSISTOR	UN4111				
						< RESISTOR >	
△R510	1-219-786-11	FUSIBLE	22 5%			1/4W F	
R511	1-249-413-11	CARBON	470 5%			1/4W	
△R520	1-219-786-11	FUSIBLE	22 5%			1/4W F	
R521	1-249-421-11	CARBON	2.2K 5%			1/4W	
R522	1-249-417-11	CARBON	1K 5%			1/4W	
△R530	1-219-153-11	FUSIBLE	10 5%			1/4W F	
R531	1-260-095-11	CARBON	470 5%			1/2W	
R562	1-249-421-11	CARBON	2.2K 5%			1/4W	
R563	1-249-409-11	CARBON	220 5%			1/4W	
R564	1-247-843-11	CARBON	3.3K 5%			1/4W	
R571	1-249-437-11	CARBON	47K 5%			1/4W	
R572	1-249-437-11	CARBON	47K 5%			1/4W	
R573	1-249-437-11	CARBON	47K 5%			1/4W	
R576	1-249-429-11	CARBON	10K 5%			1/4W	

The components identified by mark Δ or dotted line with mark Δ are critical for safety. Replace only with part number specified.	Les composants identifiés par une marque Δ sont critiques pour la sécurité. Ne les remplacer que par une pièce portant le numéro spécifié.
--	---

MAIN	MD-LED	PANEL
-------------	---------------	--------------

Ref. No.	Part No.	Description				Remark
R581	1-249-425-11	CARBON	4.7K	5%	1/4W	
R582	1-249-425-11	CARBON	4.7K	5%	1/4W	
△ R590	1-217-640-11	FUSIBLE	3.3	5%	1/4W	F
R591	1-249-425-11	CARBON	4.7K	5%	1/4W	
R592	1-249-441-11	CARBON	100K	5%	1/4W	
R593	1-249-421-11	CARBON	2.2K	5%	1/4W	
R601	1-249-429-11	CARBON	10K	5%	1/4W	
R602	1-247-807-31	CARBON	100	5%	1/4W	
R603	1-249-429-11	CARBON	10K	5%	1/4W	
R604	1-247-807-31	CARBON	100	5%	1/4W	
R605	1-249-417-11	CARBON	1K	5%	1/4W	
R606	1-247-807-31	CARBON	100	5%	1/4W	
R607	1-247-807-31	CARBON	100	5%	1/4W	
R608	1-247-807-31	CARBON	100	5%	1/4W	
R609	1-247-807-31	CARBON	100	5%	1/4W	
R610	1-247-807-31	CARBON	100	5%	1/4W	
R611	1-249-429-11	CARBON	10K	5%	1/4W	
R612	1-247-807-31	CARBON	100	5%	1/4W	
R613	1-247-807-31	CARBON	100	5%	1/4W	
R614	1-247-807-31	CARBON	100	5%	1/4W	
R615	1-249-425-11	CARBON	4.7K	5%	1/4W	
R616	1-247-843-11	CARBON	3.3K	5%	1/4W	
R617	1-249-413-11	CARBON	470	5%	1/4W	
R618	1-249-425-11	CARBON	4.7K	5%	1/4W	
R619	1-247-843-11	CARBON	3.3K	5%	1/4W	
R620	1-249-413-11	CARBON	470	5%	1/4W	
R621	1-247-843-11	CARBON	3.3K	5%	1/4W	
R622	1-247-807-31	CARBON	100	5%	1/4W	
R623	1-247-807-31	CARBON	100	5%	1/4W	
R624	1-249-429-11	CARBON	10K	5%	1/4W	
R625	1-249-429-11	CARBON	10K	5%	1/4W	
R626	1-247-807-31	CARBON	100	5%	1/4W	
R627	1-247-807-31	CARBON	100	5%	1/4W	
R628	1-249-429-11	CARBON	10K	5%	1/4W	
R630	1-249-429-11	CARBON	10K	5%	1/4W	
R631	1-249-433-11	CARBON	22K	5%	1/4W	
R632	1-249-437-11	CARBON	47K	5%	1/4W	
R633	1-249-437-11	CARBON	47K	5%	1/4W	
R634	1-249-429-11	CARBON	10K	5%	1/4W	
R635	1-247-807-31	CARBON	100	5%	1/4W	
R636	1-247-807-31	CARBON	100	5%	1/4W	
R637	1-247-807-31	CARBON	100	5%	1/4W	
R638	1-247-807-31	CARBON	100	5%	1/4W	
R639	1-247-807-31	CARBON	100	5%	1/4W	
R640	1-247-807-31	CARBON	100	5%	1/4W	
R641	1-247-807-31	CARBON	100	5%	1/4W	
R642	1-247-807-31	CARBON	100	5%	1/4W	
R643	1-247-807-31	CARBON	100	5%	1/4W	
R644	1-247-807-31	CARBON	100	5%	1/4W	
R645	1-249-425-11	CARBON	4.7K	5%	1/4W	
R646	1-247-843-11	CARBON	3.3K	5%	1/4W	
R647	1-249-429-11	CARBON	10K	5%	1/4W	
R648	1-249-413-11	CARBON	470	5%	1/4W	
R649	1-247-891-00	CARBON	330K	5%	1/4W	
R650	1-249-417-11	CARBON	1K	5%	1/4W	
R651	1-249-417-11	CARBON	1K	5%	1/4W	
R652	1-249-417-11	CARBON	1K	5%	1/4W	
R653	1-249-417-11	CARBON	1K	5%	1/4W	

Ref. No.	Part No.	Description				Remark
R654	1-249-417-11	CARBON	1K	5%	1/4W	
R655	1-249-417-11	CARBON	1K	5%	1/4W	
R656	1-249-417-11	CARBON	1K	5%	1/4W	
R801	1-249-417-11	CARBON	1K	5%	1/4W	
R807	1-247-807-31	CARBON	100	5%	1/4W	
R821	1-249-441-11	CARBON	100K	5%	1/4W	
R822	1-249-417-11	CARBON	1K	5%	1/4W	
R825	1-249-429-11	CARBON	10K	5%	1/4W	
R826	1-249-429-11	CARBON	10K	5%	1/4W	
R831	1-249-441-11	CARBON	100K	5%	1/4W	
R832	1-249-417-11	CARBON	1K	5%	1/4W	
R851	1-249-421-11	CARBON	2.2K	5%	1/4W	
R852	1-249-431-11	CARBON	15K	5%	1/4W	
R861	1-249-421-11	CARBON	2.2K	5%	1/4W	
R862	1-249-431-11	CARBON	15K	5%	1/4W	
R871	1-249-421-11	CARBON	2.2K	5%	1/4W	
R872	1-249-441-11	CARBON	100K	5%	1/4W	
R873	1-247-887-00	CARBON	220K	5%	1/4W	
R874	1-249-421-11	CARBON	2.2K	5%	1/4W	
R875	1-249-441-11	CARBON	100K	5%	1/4W	
R876	1-247-887-00	CARBON	220K	5%	1/4W	
R881	1-247-903-00	CARBON	1M	5%	1/4W	
< VIBRATOR >						
X601	1-760-489-11	VIBRATOR, CERAMIC (5MHz)				
X602	1-567-098-41	VIBRATOR, CRYSTAL (32kHz)				

*	1-666-899-11	MD-LED BOARD				

< LED >						
D905	8-719-057-09	LED LNJ801LPDJA (MD INDICATOR)				

*	A-4403-402-A	PANEL BOARD, COMPLETE				

*	4-993-866-01	HOLDER (FL)				
< CAPACITOR >						
C901	1-162-306-11	CERAMIC	0.01uF	20%	16V	
C902	1-162-306-11	CERAMIC	0.01uF	20%	16V	
C903	1-126-160-11	ELECT	1uF	20%	50V	
C923	1-164-159-11	CERAMIC	0.1uF		50V	
C935	1-124-261-00	ELECT	10uF	20%	50V	
C936	1-124-234-00	ELECT	22uF	20%	16V	
C937	1-164-159-11	CERAMIC	0.1uF		50V	
C940	1-162-282-31	CERAMIC	100PF	10%	50V	
C946	1-164-159-11	CERAMIC	0.1uF		50V	
C948	1-162-286-31	CERAMIC	220PF	10%	50V	
C949	1-162-286-31	CERAMIC	220PF	10%	50V	
C950	1-162-286-31	CERAMIC	220PF	10%	50V	
C951	1-162-286-31	CERAMIC	220PF	10%	50V	
C952	1-162-286-31	CERAMIC	220PF	10%	50V	
C953	1-162-286-31	CERAMIC	220PF	10%	50V	
C954	1-162-286-31	CERAMIC	220PF	10%	50V	
C955	1-162-286-31	CERAMIC	220PF	10%	50V	
C956	1-162-286-31	CERAMIC	220PF	10%	50V	

<p>The components identified by mark △ or dotted line with mark △ are critical for safety. Replace only with part number specified.</p>	<p>Les composants identifiés par une marque △ sont critiques pour la sécurité. Ne les remplacer que par une pièce portant le numéro spécifié.</p>
---	---

PANEL

Ref. No.	Part No.	Description	Remark	Ref. No.	Part No.	Description	Remark
C957	1-162-286-31	CERAMIC	220PF 10% 50V	R913	1-249-421-11	CARBON 2.2K 5% 1/4W	
C958	1-162-286-31	CERAMIC	220PF 10% 50V	R914	1-247-807-31	CARBON 100 5% 1/4W	
C959	1-162-286-31	CERAMIC	220PF 10% 50V	R915	1-249-409-11	CARBON 220 5% 1/4W	
C960	1-162-286-31	CERAMIC	220PF 10% 50V	R916	1-247-807-31	CARBON 100 5% 1/4W	
C961	1-162-286-31	CERAMIC	220PF 10% 50V	R917	1-247-807-31	CARBON 100 5% 1/4W	
C962	1-162-286-31	CERAMIC	220PF 10% 50V	R918	1-249-409-11	CARBON 220 5% 1/4W	
C964	1-126-160-11	ELECT	1uF 20% 50V	R919	1-247-807-31	CARBON 100 5% 1/4W	
C965	1-124-589-11	ELECT	47uF 20% 16V	R920	1-247-807-31	CARBON 100 5% 1/4W	
C966	1-162-294-31	CERAMIC	0.001uF 10% 50V	R921	1-247-807-31	CARBON 100 5% 1/4W	
C1401	1-162-294-31	CERAMIC	0.001uF 10% 50V	R922	1-247-807-31	CARBON 100 5% 1/4W	
C1402	1-162-294-31	CERAMIC	0.001uF 10% 50V	R923	1-249-437-11	CARBON 47K 5% 1/4W	
C1404	1-164-159-11	CERAMIC	0.1uF 50V	R924	1-249-407-11	CARBON 150 5% 1/4W	
< CONNECTOR >				R925	1-249-407-11	CARBON 150 5% 1/4W	
* CN901	1-568-865-11	SOCKET, CONNECTOR 23P		R926	1-249-437-11	CARBON 47K 5% 1/4W	
< DIODE >				R927	1-249-437-11	CARBON 47K 5% 1/4W	
D901	8-719-010-43	DIODE UZ-5.6BSC		R928	1-249-411-11	CARBON 330 5% 1/4W	
D902	8-719-058-03	LED SEL5423E-TP15 (▶ (MD))		R929	1-249-437-11	CARBON 47K 5% 1/4W	
D903	8-719-057-97	LED SEL5923A-TP15 (■ (MD))		R930	1-249-411-11	CARBON 330 5% 1/4W	
D904	8-719-057-09	LED LNJ801LPDJA (●)		R931	1-249-437-11	CARBON 47K 5% 1/4W	
D906	8-719-058-03	LED SEL5423E-TP15 (▶ (CD))		R932	1-249-407-11	CARBON 150 5% 1/4W	
D907	8-719-057-97	LED SEL5923A-TP15 (■ (CD))		R933	1-249-407-11	CARBON 150 5% 1/4W	
D908	8-719-057-09	LED LNJ801LPDJA (CD INDICATOR)		R934	1-249-437-11	CARBON 47K 5% 1/4W	
< FLUORESCENT INDICATOR TUBE >				R935	1-249-437-11	CARBON 47K 5% 1/4W	
FL901	1-517-687-11	INDICATOR TUBE, FLUORESCENT		R936	1-249-409-11	CARBON 220 5% 1/4W	
< IC >				R937	1-249-393-11	CARBON 10 5% 1/4W	
IC901	8-759-297-23	IC M66004M8FP		R938	1-249-393-11	CARBON 10 5% 1/4W	
IC902	8-759-459-83	IC NJL55H400		R941	1-249-413-11	CARBON 470 5% 1/4W	
< JACK >				R942	1-249-415-11	CARBON 680 5% 1/4W	
J1400	1-764-106-21	JACK (PHONES)		R943	1-249-417-11	CARBON 1K 5% 1/4W	
< TRANSISTOR >				R944	1-249-419-11	CARBON 1.5K 5% 1/4W	
Q901	8-729-620-05	TRANSISTOR 2SC2603-EF		R945	1-249-421-11	CARBON 2.2K 5% 1/4W	
Q902	8-729-620-05	TRANSISTOR 2SC2603-EF		R946	1-249-413-11	CARBON 470 5% 1/4W	
Q904	8-729-422-57	TRANSISTOR UN4111		R947	1-249-415-11	CARBON 680 5% 1/4W	
Q905	8-729-422-57	TRANSISTOR UN4111		R948	1-249-417-11	CARBON 1K 5% 1/4W	
Q906	8-729-422-57	TRANSISTOR UN4111		R949	1-249-419-11	CARBON 1.5K 5% 1/4W	
Q907	8-729-422-57	TRANSISTOR UN4111		R950	1-249-421-11	CARBON 2.2K 5% 1/4W	
Q908	8-729-422-57	TRANSISTOR UN4111		R951	1-249-425-11	CARBON 4.7K 5% 1/4W	
Q909	8-729-422-57	TRANSISTOR UN4111		R952	1-249-430-11	CARBON 12K 5% 1/4W	
Q910	8-729-422-57	TRANSISTOR UN4111		< SWITCH >			
< RESISTOR >				S901	1-467-869-11	ENCODER, ROTARY (VOLUME)	
R901	1-249-441-11	CARBON	100K 5% 1/4W	S902	1-554-303-21	SWITCH, TACTILE (POWER)	
R902	1-249-441-11	CARBON	100K 5% 1/4W	S903	1-554-303-21	SWITCH, TACTILE (CD ■)	
R903	1-249-417-11	CARBON	1K 5% 1/4W	S904	1-554-303-21	SWITCH, TACTILE (CD ▶▶■)	
R904	1-249-417-11	CARBON	1K 5% 1/4W	S905	1-554-303-21	SWITCH, TACTILE (≡ (CD))	
R907	1-249-441-11	CARBON	100K 5% 1/4W	S906	1-554-303-21	SWITCH, TACTILE (MD ■)	
R908	1-249-435-11	CARBON	33K 5% 1/4W	S907	1-554-303-21	SWITCH, TACTILE (MD ▶▶■)	
R909	1-249-417-11	CARBON	1K 5% 1/4W	S908	1-554-303-21	SWITCH, TACTILE (≡ (MD))	
R910	1-249-417-11	CARBON	1K 5% 1/4W	S909	1-554-303-21	SWITCH, TACTILE (FUNCTION)	
R911	1-249-417-11	CARBON	1K 5% 1/4W	S910	1-554-303-21	SWITCH, TACTILE	(MD/CD ▶▶▶▶, TUNER +)
R912	1-249-417-11	CARBON	1K 5% 1/4W	S911	1-554-303-21	SWITCH, TACTILE (TUNER/BAND)	
				S912	1-554-303-21	SWITCH, TACTILE	(MD/CD ◀◀◀◀, TUNER -)
				S913	1-554-303-21	SWITCH, TACTILE (● REC)	
				S914	1-554-303-21	SWITCH, TACTILE (CD-MD SYNC)	
				S915	1-554-303-21	SWITCH, TACTILE (REPEAT, STEREO/MONO)	

PANEL

POWER AMP

ST TERMINAL

Ref. No.	Part No.	Description	Remark
S916	1-554-303-21	SWITCH, TACTILE (PLAY MODE, TUNING MODE)	

*	A-4403-410-A	POWER AMP BOARD, COMPLETE (AEP, UK, G, AED)	
*	A-4403-417-A	POWER AMP BOARD, COMPLETE (MY, SP, HK)	
*	A-4407-385-A	POWER AMP BOARD, COMPLETE (CND) *****	
< CAPACITOR >			
C1201	1-126-963-11	ELECT 4.7uF 20% 50V	
C1202	1-162-288-31	CERAMIC 330PF 10% 50V	
C1203	1-162-286-31	CERAMIC 220PF 10% 50V	
C1204	1-126-967-11	ELECT 47uF 20% 50V	
C1205	1-126-967-11	ELECT 47uF 20% 50V	
C1206	1-126-948-11	ELECT 100uF 20% 35V	
C1207	1-136-165-00	FILM 0.1uF 5% 50V	
C1208	1-126-965-11	ELECT 22uF 20% 50V	
C1210	1-136-163-00	FILM 0.068uF 5% 50V	
C1211	1-136-163-00	FILM 0.068uF 5% 50V	
C1220	1-126-924-11	ELECT 330uF 20% 10V	
C1251	1-126-963-11	ELECT 4.7uF 20% 50V	
C1252	1-162-288-31	CERAMIC 330PF 10% 50V	
C1253	1-162-286-31	CERAMIC 220PF 10% 50V	
C1254	1-126-967-11	ELECT 47uF 20% 50V	
C1255	1-126-967-11	ELECT 47uF 20% 50V	
C1256	1-126-948-11	ELECT 100uF 20% 35V	
C1257	1-136-165-00	FILM 0.1uF 5% 50V	
C1260	1-136-163-00	FILM 0.068uF 5% 50V	
C1261	1-136-163-00	FILM 0.068uF 5% 50V	
C1301	1-126-042-11	ELECT 3300uF 20% 35V	
C1302	1-126-042-11	ELECT 3300uF 20% 35V	
C1303	1-136-165-00	FILM 0.1uF 5% 50V	
C1304	1-136-165-00	FILM 0.1uF 5% 50V	
< CONNECTOR >			
* CN1202	1-565-485-11	CONNECTOR, BOARD TO BOARD 9P	
< DIODE >			
D1201	8-719-911-19	DIODE 1SS119	
D1202	8-719-911-19	DIODE 1SS119	
D1203	8-719-911-19	DIODE 1SS119	
D1213	8-719-911-19	DIODE 1SS119	
D1251	8-719-911-19	DIODE 1SS119	
D1263	8-719-911-19	DIODE 1SS119	
D1300	8-719-025-03	DIODE RBA-402-SL	
< IC >			
IC1201	8-749-920-13	IC STK-4132MK2	
< TRANSISTOR >			
Q1201	8-729-620-05	TRANSISTOR 2SC2603-EF	
Q1202	8-729-900-80	TRANSISTOR DTC114ES	
Q1231	8-729-422-73	TRANSISTOR UN4212	
Q1232	8-729-620-05	TRANSISTOR 2SC2603-EF	
Q1251	8-729-620-05	TRANSISTOR 2SC2603-EF	

Ref. No.	Part No.	Description	Remark
< RESISTOR >			
R1201	1-249-417-11	CARBON 1K 5%	1/4W
R1202	1-249-437-11	CARBON 47K 5%	1/4W
R1203	1-249-417-11	CARBON 1K 5%	1/4W
R1204	1-249-437-11	CARBON 47K 5%	1/4W
R1205	1-260-103-11	CARBON 2.2K 5%	1/2W
R1207	1-260-103-11	CARBON 2.2K 5%	1/2W
△R1209	1-212-881-11	FUSIBLE 100	5% 1/4W F
△R1210	1-217-151-00	RES, METAL PLATE	0.22 2W F
R1211	1-249-417-11	CARBON 1K 5%	1/4W
R1212	1-249-431-11	CARBON 15K 5%	1/4W
R1214	1-260-099-11	CARBON 1K 5%	1/2W
R1217	1-260-099-11	CARBON 1K 5%	1/2W
R1218	1-249-397-11	CARBON 22 5%	1/4W
R1219	1-249-397-11	CARBON 22 5%	1/4W
R1225	1-249-397-11	CARBON 22 5%	1/4W
R1226	1-249-429-11	CARBON 10K 5%	1/4W
R1227	1-247-854-11	CARBON 9.1K 5%	1/4W
R1227	1-249-429-11	CARBON 10K 5%	1/4W (EXCEPT CND)
R1228	1-247-880-11	CARBON 110K 5%	1/4W (CND)
R1228	1-249-441-11	CARBON 100K 5%	1/4W (AEP, UK, G, AED)
R1229	1-249-429-11	CARBON 10K 5%	1/4W (CND, MY, SP, HK)
R1231	1-247-807-31	CARBON 100 5%	1/4W
R1232	1-249-429-11	CARBON 10K 5%	1/4W
R1233	1-249-429-11	CARBON 10K 5%	1/4W
△R1243	1-217-637-00	FUSIBLE 1	5% 1/4W F
R1251	1-249-417-11	CARBON 1K 5%	1/4W
R1252	1-249-437-11	CARBON 47K 5%	1/4W
R1253	1-249-417-11	CARBON 1K 5%	1/4W
R1254	1-249-437-11	CARBON 47K 5%	1/4W
R1255	1-260-103-11	CARBON 2.2K 5%	1/2W
R1257	1-260-103-11	CARBON 2.2K 5%	1/2W
△R1259	1-212-881-11	FUSIBLE 100	5% 1/4W F
△R1260	1-217-151-00	RES, METAL PLATE	0.22 2W F
R1261	1-249-417-11	CARBON 1K 5%	1/4W
R1262	1-249-431-11	CARBON 15K 5%	1/4W
R1268	1-249-397-11	CARBON 22 5%	1/4W
R1269	1-249-397-11	CARBON 22 5%	1/4W
R1271	1-249-431-11	CARBON 15K 5%	1/4W
R1272	1-249-431-11	CARBON 15K 5%	1/4W
R1273	1-249-413-11	CARBON 470 5%	1/4W
< THERMISTOR >			
THP12301-807-796-11	THERMISTOR		

*	1-666-905-11	ST TERMINAL BOARD	*****
< CONNECTOR >			
CN744	1-568-834-11	SOCKET, CONNECTOR 15P	
CN745	1-774-289-11	PIN, CONNECTOR (PC BOARD) 15P	

The components identified by mark △ or dotted line with mark △ are critical for safety. Replace only with part number specified.	Les composants identifiés par une marque △ sont critiques pour la sécurité. Ne les remplacer que par une pièce portant le numéro spécifié.
--	--

SW	TRANSFORMER
-----------	--------------------

Ref. No.	Part No.	Description	Remark
*	1-667-719-11	SW BOARD *****	
		< CONNECTOR >	
CN601	1-770-697-11	CONNECTOR, FFC/FPC 14P	
CN602	1-778-638-21	PIN, CONNECTOR (PC BOARD) 2P	
CN603	1-778-638-21	PIN, CONNECTOR (PC BOARD) 2P	
		< SWITCH >	
S681	1-572-467-61	SWITCH, PUSH (1 KEY) (LIMIT IN)	
S682	1-692-377-31	SWITCH, PUSH (1 KEY) (REFLECT)	
S683	1-692-847-21	SWITCH, PUSH (1 KEY) (PROTECT)	
S685	1-572-467-61	SWITCH, PUSH (1 KEY) (CHUCKING IN)	
S686	1-762-621-21	SWITCH, PUSH (1 KEY) (PACK OUT)	
S687	1-572-688-11	SWITCH, PUSH (1 KEY) (PB POSITION)	
S688	1-762-621-21	SWITCH, PUSH (1 KEY) (REC POSITION)	

*	1-666-904-11	TRANSFORMER BOARD *****	
	1-533-293-11	FUSE HOLDER	
		< CONNECTOR >	
CN1600	1-564-321-00	PIN, CONNECTOR 2P	
* CN1601	1-564-518-11	PLUG, CONNECTOR 3P	
CN1602	1-564-523-11	PLUG, CONNECTOR 8P	
		< FUSE >	
△ F1601	1-532-388-31	FUSE (T2AL/250V) (MY, SP, HK)	
△ F1603	1-532-504-31	FUSE (T4AL/250V) (EXCEPT CND)	
△ F1603	1-533-419-11	FUSE, GLASS CYLINDRICAL (4A/125V) (CND)	
△ F1605	1-532-504-31	FUSE (T4AL/250V) (EXCEPT CND)	
△ F1605	1-533-419-11	FUSE, GLASS CYLINDRICAL (4A/125V) (CND)	
		< RESISTOR >	
△ R1600	1-202-725-00	SOLID 3.3M 10% 1/2W F (CND)	
		< SWITCH >	
△ S1600	1-762-753-11	SWITCH, VOLTAGE SELECTION (VOLTAGE SELECTOR) (MY, SP, HK)	
		< THERMISTOR (POSITIVE) >	
THP16001-801-696-11		THERMISTOR, POSITIVE	
THP16011-801-696-11		THERMISTOR, POSITIVE	
THP16021-801-671-11		THERMISTOR, POSITIVE	
THP16031-801-671-11		THERMISTOR, POSITIVE	

		MISCELLANEOUS *****	
10	1-782-793-11	WIRE (FLAT TYPE) (23 CORE)	
52	1-782-990-11	WIRE (FLAT TYPE) (19 CORE)	
56	1-782-991-11	WIRE (FLAT TYPE) (15 CORE) (10 cm)	
62	1-233-544-21	ENCAPSULATED COMPONENT (CND)	
62	1-233-546-21	ENCAPSULATED COMPONENT (MY, SP, HK)	
62	1-693-387-21	TUNER (FM/MW/LW) (AEP, UK, G, AED)	
64	1-783-213-11	WIRE (FLAT TYPE) (15 CORE): BEND (10 cm)	

Ref. No.	Part No.	Description	Remark
△ 68	1-569-008-11	ADAPTOR, CONVERSION 2P (MY, SP)	
△ 69	1-770-019-11	ADAPTOR, CONVERSION PLUG 3P (HK)	
103	1-782-683-11	WIRE (FLAT TYPE) (14 CORE)	
110	1-782-792-11	WIRE (FLAT TYPE) (25 CORE)	
△ 167	8-583-028-02	OPTICAL PICK-UP KMS-260A/J1N (for MD)	
△ 255	8-848-367-11	OPTICAL PICK-UP KSS-213B/K-N (for CD)	
256	1-769-069-11	WIRE (FLAT TYPE) (16 CORE)	
△ CNP1601	1-751-520-11	CORD, POWER (CND)	
△ CNP1601	1-696-570-21	CORD, POWER (UK)	
△ CNP1601	1-769-744-11	CORD, POWER (EXCEPT CND, UK)	
FAN901	1-698-997-11	FAN, DC	
HR901	1-500-396-11	HEAD, OVER LIGHT (RF325-74A)	
M101	X-4917-523-4	BASE (OUTSART) ASSY (SPINDLE)	
M102	X-4917-504-1	MOTOR ASSY (SLED)	
M901	A-4672-135-A	MOTOR ASSY, SPINDLE	
M902	A-4672-133-A	MOTOR ASSY, SLED	
M903	A-4608-362-A	MOTOR (L) ASSY (LOADING) (CD)	
M903	A-4672-134-A	MOTOR ASSY, LOADING (MD)	
△ T1600	1-431-497-11	TRANSFORMER, POWER (AEP, UK, G, AED)	
△ T1600	1-431-498-11	TRANSFORMER, POWER (MY, SP, HK)	
△ T1600	1-431-756-11	TRANSFORMER, POWER (CND)	

***** HARDWARE LIST *****			
#1	7-685-646-79	SCREW +BVTP 3X8 TYPE2 N-S	
#2	7-685-647-79	SCREW +BVTP 3X10 TYPE2 N-S	
#3	7-685-650-79	SCREW +BVTP 3X16 TYPE2 IT-3	
#4	7-685-871-01	SCREW +BVTT 3X6	
#5	7-685-850-04	SCREW +BVTT 2X3 (S)	
#6	7-685-851-04	SCREW +BVTT 2X4 (S)	
#7	7-627-553-17	PRECISION SCREW +P 2X2 TYPE 3	
#8	7-627-552-27	SCREW, PRECISION +P 1.7X2	
#9	7-624-105-04	STOP RING 2.3, TYPE-E	
#10	7-685-234-19	SCREW +KTP 2.6X8 TYPE2 NON-SLIT	
#11	7-621-775-10	SCREW +B 2.6X4	
#12	7-621-255-15	SCREW +P 2X3	
#13	7-627-852-28	+P 1.7X3	

The components identified by mark △ or dotted line with mark △ are critical for safety. Replace only with part number specified.	Les composants identifiés par une marque △ sont critiques pour la sécurité. Ne les remplacer que par une pièce portant le numéro spécifié.
--	--

